

Operating Instructions



F00034y



Terrabox TCB030 Terracompact II TCO030

for TUE30 Terra-Control Ground Monitoring System

BA-en-4003-2501



List of contents

1	TUE30 Terra-Control Ground Monitoring System	
	Overview of Appliance	6
1.1	Components	7
1.2	Variants	7
2	Safety	8
2.1	Identification of risks and hazards	8
2.2	Technical advance	8
2.3	Proper use	8
2.4	Work and operational safety	9
2.5	Special arrangements according to the declaration of conformity	11
3	Assembly and installation	12
3.1	Terrabox TCB030	12
3.1.1	View of appliance	12
3.1.2	Assembly	13
3.1.3	Electrical connections	14
3.2	Terracompact II TCO030	20
3.2.1	Assembly	20
3.2.2	Electrical connections	20
3.2.3	Power supply TCON01	25
3.3	Supply voltage	25
3.4	Cable specification	25
4	Operation	26
4.1	Start-up	26
4.2	Function	26
4.3	Operation with 2 ground contactors, Big-Bag grounding	27
4.3.1	Before connecting the two ground contactors, the BIG-BAG has no connection to ground potential	27
4.3.2	Before connecting the two ground contactors, the BIG-BAG is already connected to ground potential	27
4.4	Switching states of the relays in overview (Contact circuit indicator signal)	28
4.5	Function control	28
5	Maintenance	29
5.1	Ground control units	29
5.2	Ground contactors	29
5.3	Cable rewinders	30
6	Troubleshooting	31

7	Technical specifications	31
7.1	Terrabox TCB030	31
7.2	Terracompact II TCO030	33
7.3	Power supply TCON01	34
8	Dimensions	35
9	Accessories and spare parts	37
A.	Annex	39
A.1	Grounding with ground monitoring unit (active grounding)	39
A.2	Grounding without ground monitoring unit (passive grounding)	40
A.3	Overview Approvals	41
	Declarations of Conformity	42

Dear customer,

The controlled grounding principle used in the TUE Terra-Control Ground Monitoring System ensures that static charges developing in potentially explosive atmospheres, e.g. during loading, discharging or refilling are safely avoided. This means that the risk of ignition caused by uncontrolled static discharges is eliminated at source.

No impedance grounding and no large conductor diameters, normally needed in electrical machine construction, are required.

Static charges are caused by the contact and separation of material surfaces, e.g. when pumping liquid or powdery materials from one container to another. If no leakage device is available to lead these charges to ground, extremely high charge potentials may develop. Deflagrations or even explosions caused by sparking can result in substantial damage or personal injury.

Objects are considered to be adequately grounded if their ground leakage resistance is not greater than $10^5 \dots 10^8 \Omega$. The Eltex Terra-Control Ground Monitoring System guarantees a safe and reliable ground connection. Used in combination with the Eltex ground clamps / contactors and the cable rewinders the system provides the ultimate ground connection.

The Terra-Control components monitor the connection to the bonding conductor and the contact across the ground contactors. This function is controlled by a relay. This relay allows an isolation mechanism to be implemented which, as long as the ground contactor is connected to the container or bin, releases the filling or refilling process, for instance. If the contactor is removed or slips off, or if the ground connection is interrupted, filling stops automatically.

Please read these instructions carefully before starting the unit. This will help you prevent personal injuries and damage to property.

Simply give us a call if you have any suggestions, proposals or ideas for improvements. We greatly appreciate the feedback from the users of our appliances.

1.1 Components

Terrabox TCB030

for installation in explosion hazard areas;
operating voltage 24 V DC or 115 / 230 V AC depending on design;
for connecting a clamp (two clamps for BIG-BAG grounding).

Terracompact II TCO030

for mounting on a standard rail NS35 in dry control rooms;
operating voltage 24 V DC;
for connecting a clamp (two clamps for BIG-BAG grounding).

Power supply TCON01

100...240 V AC, for supplying a maximum of 2 Terracompact II TCO030.

601KR/AW, 601KR/DW, 601KR/KW cable rewinders,

see separate Operating Instructions BA-en-4007

Series 70 ground clamps

see separate Operating Instructions BA-en-4017

TERRACLAMP ground clamps

see separate Operating Instructions BA-en-4014

1.2 Variants

Terrabox TCB030:

Standard (1 ground contactor)

- TCB030/S0 24 V DC
- TCB030/S1 115 V AC
- TCB030/S2 230 V AC
- Operating points: ON <20 kOhm, OFF >50 kOhm \pm 20 %

BIG-BAG (1 ground contactor):

- TCB030/B0 24 V DC
- TCB030/B1 115 V AC
- TCB030/B2 230 V AC
- Operating points: ON <50 MOhm, OFF >100 MOhm \pm 20 %

BIG-BAG (2 ground contactor):

- TCB030/20 24 V DC
- TCB030/21 115 V AC
- TCB030/22 230 V AC
- Operating points: ON <50 MOhm, OFF >100 MOhm \pm 20 %

Terracompact II TCO030:

Standard: TCO030S

BIG-BAG: TCO030B

Power Supply TCON01 for Terracompact II TCO030

2. Safety

The units have been designed, built and tested using state-of-the-art engineering, and have left the factory in a technically and operationally safe condition. If used improperly, the units may nevertheless be hazardous to personnel and may cause injury or damage. Read the operating instructions carefully and observe the safety instructions.

For warranty conditions, please refer to the General Terms and Conditions (GTC), see www.eltex.de.

2.1 Identification of risks and hazards

Possible risks and hazards resulting from the use of the units are referred to in these operating instructions by the following symbols:



Warning!

This symbol appearing in the operating instructions refers to operations which, if carried out improperly, may result in serious personal injuries.



Caution!

This symbol appearing in the operating instructions refers to operations which, if carried out improperly, may result in damage to property.



Ex Warning!

Only for units with Ex approval.

This symbol denotes the special conditions which must be observed when operating the units in explosion hazard areas as specified in the approvals.

2.2 Technical advance

The manufacturer reserves the right to make changes to the technical specifications without prior notice in order to adapt the units to state-of-the-art engineering. Eltex will provide the latest information on any changes or modifications in the operating instructions on request.

2.3 Proper use

The TUE Terra-Control Ground Monitoring System must be operated only for the purpose of static ground connection.

The active component Terracompact II TCO030 is an associated electrical device in accordance to the standards EN 60079-0 and EN 60079-11 and must be placed outside the explosion hazard area. The Terrabox TCB030 component is approved for installation in the explosion hazard area (see chapter 7 Technical specifications).

The Terra-Control ground monitoring systems are designed for operation with specific Eltex contact clamps of the Series 70 and **TERRACLAMP** as

well as 601KR/_ cable rewinders. These contact clamps provide high degree of safety and the best possible ground connection in terms of static electricity.

The manufacturers will not assume any liability and warranty if the units are used improperly or used outside the intended purpose.

Modifications or changes made to the devices are not permitted.

Use only original Eltex spare parts and equipment.

2.4 Work and operational safety



Warning!

Carefully observe the following notes and the complete [chapter 2 "Safety", page 8!](#)

- The local standards, rules and regulations relating to the installation and operation of electrical appliances in potentially explosive atmospheres must be observed (e.g. EN 60079-14 and EN 60079-17 in the EU and ElexV in Germany).
- Appliances designed for use in potentially explosive atmospheres must not be modified. The technical specifications for ambient conditions and operation must be maintained and observed (see [chapter 7 "Technical specifications", page 31](#)).
- Any work involving the units must be carried out by qualified electricians (see [chapter 3 "Assembly and installation", page 12](#), [chapter 5 "Maintenance", page 29](#), [chapter 6 "Troubleshooting", page 31](#)).
- The unit may only be used by qualified personnel trained for explosion hazard areas.
- A "Connect/Disconnect Approval" by the plant operator must be obtained before carrying out any installation, assembly, service, repair or maintenance work in potentially explosive atmospheres. Make sure that there is no potentially explosive atmosphere prevailing in the working area (see [chapter 3 "Assembly and installation", page 12](#), [chapter 5 "Maintenance", page 29](#)).
- Electrical systems used in explosion hazard areas must at all times be in a technically faultless condition. Any defects must be repaired or remedied immediately (see [chapter 4 "Operation", page 26](#)).
- The point of installation of the TCB030 Terrabox must be dry and the indicator lamp must remain in full view. Avoid direct exposure to sunlight (see [chapter 3.1.2 "Assembly", page 13](#)).
- The unit must be connected to the equipotential bond via the external ground terminal (7, Fig. 4 / Fig. 5). In addition, the ground terminal inside the enclosure must be connected to a PE conductor or a bonding conductor (see [chapter 3.1.2 "Assembly", page 13](#)).

- Intrinsically safe circuits must be routed separately from non-intrinsically safe circuits (separate cable conduits/ducts). Crossing intrinsically safe and non-intrinsically safe leads is not permitted. An equipotential bonding connection (PA) must be established along the entire intrinsically safe measuring circuit (see [chapter 3.1.3 "Electrical connections", page 14](#), [chapter 3.2.2 "Electrical connections", page 20](#)).
- The maximum cable length in the intrinsically safe circuit must not exceed the maximum rated capacity and inductance (see Technical Specifications), see [chapter 3.1.3 "Electrical connections", page 14](#), [chapter 3.2.2 "Electrical connections", page 20](#)).
- A potential equalization system (PA) has to be set up along the complete measuring circuit (see [chapter 3.1.3 "Electrical connections", page 14](#)).
- The Terracompact II TCO030 must be mounted outside the hazardous area. Only the intrinsically safe circuit is allowed to lead into the hazardous area (see [chapter 3.2.1 "Assembly", page 20](#)).
- If a TCO30 or TCB030 is supplied with 24 V, make sure that the supply (24 V) is ungrounded. If required, the negative connection can be connected with PAL (see [chapter 3.3 "Supply voltage", page 25](#)).
- If the ground cable is subjected to tensile stress in the application (e.g. if KG/BN_ (ground cable) or KG/BS_ (helix ground cable) is used), the cable must be secured additionally with an external strain relief (e.g. a strap clip), see [chapter 3.4 "Cable specification", page 25](#).
- Please note the type plate indicating the connection data (supply voltage) of the units (see [chapter 4 "Operation", page 26](#)).
- During operation with 2 ground contactors, it is not only the ground link of the BIG-BAG which is being monitored, but also the conductivity of the BIG-BAG. Note that both ground contactors are connected to two different grounding points of the BIG-BAG (see [chapter 4.3 "Operation with 2 ground contactors. BIG-BAG grounding", page 27](#)).
- Cables and ground contactors must not be damaged. Damaged cables and contactors must be replaced with new parts (see [chapter 5 "Maintenance", page 29](#)).
- Check the units at regular intervals for proper function, in doing so check the operating points and the earthing resistance (see [chapter 5.1 "Ground control units", page 29](#)).
- To make sure that the proper ground connection exists with the equipotential bonding and that no malfunctions occur with active ground contactors, the ground contactor must be cleaned when dirty (see [chapter 5.2 "Ground contactors", page 29](#)).
- Store the ground contactor such that it cannot be damaged. Replace damaged cables and contactors with new parts. Whenever possible, the ground contactor should either be hung up freely or be clamped to a non-conductive object (see [chapter 5.2 "Ground contactors", page 29](#)).

- Perform regular checks to ensure that the cable and the insulation show no tears or abrasion that could impair the cable's insulation or functioning (see [chapter 5.3 "Cable rewinders", page 30](#)).



2.5 Special arrangements according to the declaration of conformity

- A potential equalization system (PA) has to be set up along the complete measuring circuit.
- In areas in which dust is likely to cause explosive atmospheres, only appropriately certified equipment marked "D" may be connected to the measuring circuit.
- In areas in which gas is likely to cause explosive atmospheres, simple electrical apparatus like clamps and cable rewinders may be connected to the measuring circuit. The simple apparatus must comply with the appropriate requirements of EN 60079-11, but must not be certified and marked.
- The intrinsically safe measuring circuit may also be guided into the explosion hazard zone in which Class 1 operational equipment is required. In this zone, sparks generated under field conditions by the use of connected equipment (e.g. measuring clamp) are not permitted.

3. Assembly and installation

3.1 Terrabox TCB030

3.1.1 View of appliance

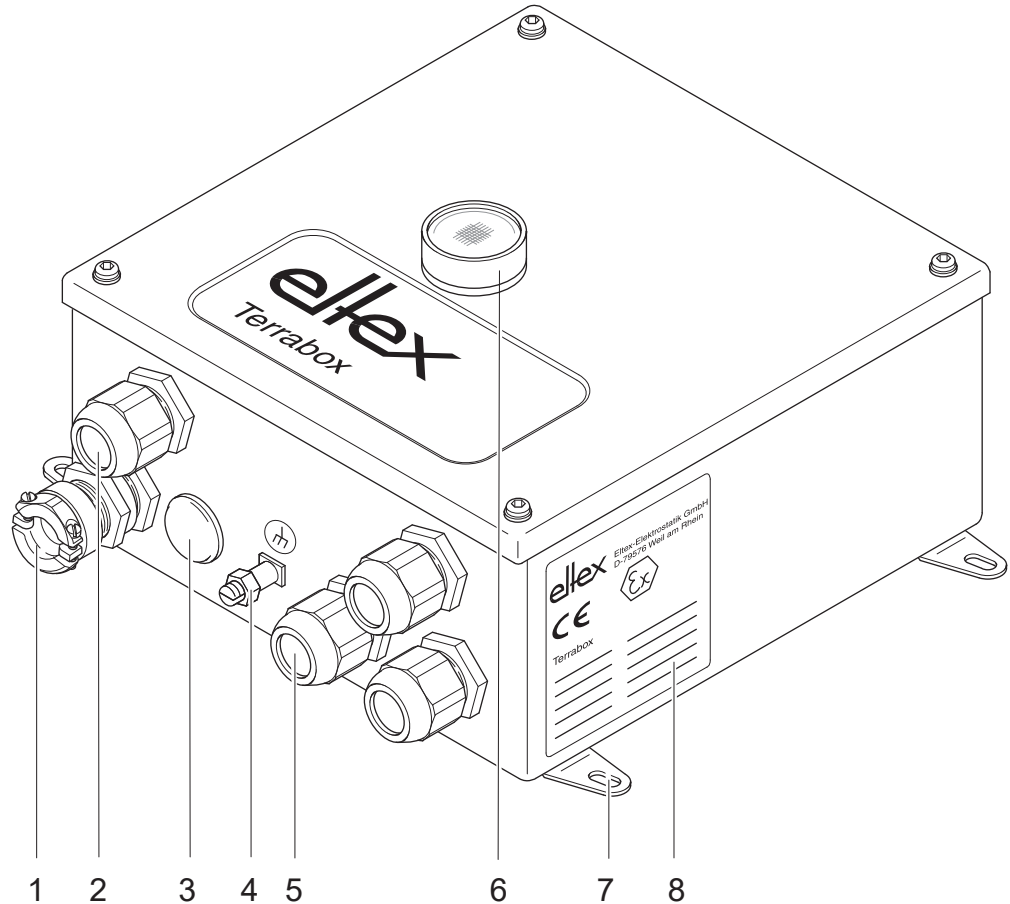

Fig. 2:
Terrabox TCB030

- 1 Cable gland with kink guard (Ex), (2x for BIG-BAG grounding)
- 2 Cable inlet
- 3 Blanking plug
- 4 Ground terminal
- 5 Cable inlet (3x)
- 6 Indicator lamp, dual color (green/red)
- 7 Mounting bracket (4x)
- 8 Type plate

Z00031y

3.1.2 Assembly



When installing the system in explosion hazard areas, every precaution must be taken to ensure that no explosive atmosphere exists in the working area!

The Terrabox TCB030 is approved for assembly and installation in potentially explosive atmospheres. The system is designed for wall mounting and is attached with the mounting brackets provided.



The point of installation must be dry and the indicator lamp must remain in full view. Avoid direct exposure to sunlight.

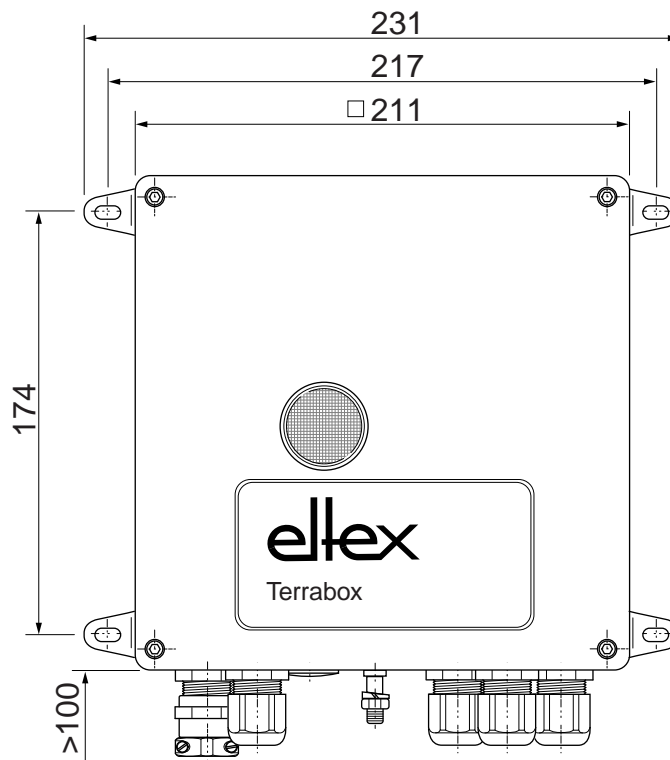

Fig. 3:
Mounting dimensions Terrabox

z00032y

3.1.3 Electrical connections



When installing the system in explosion hazard areas, every precaution must be taken to ensure that no explosive atmosphere exists in the working area!

The unit must always be connected to the equipotential bond via the external ground terminal (7, Fig. 4 / Fig. 5). In addition, the ground terminal inside the enclosure must be connected to a PE conductor or a bonding conductor.

The connection space of the unit is accessible after opening the cover of the enclosure. The terminals for the clamps are located on the left. These circuits are intrinsically safe. The non-intrinsically safe terminals for the supply voltage and the signal contacts are located on the right (see Fig. 4 / Fig. 5).



The connecting leads inside the connection space must be routed such that intrinsically safe and non-intrinsically safe leads do not make contact even if a wire should come loose. Use cable ties, if necessary.

The cable glands are designed for cables with circular cross-section and outer diameter of 6...12 mm.

- To connect the cable, first loosen the union nut of the screw connection and, if necessary, remove the blind plug.
- Insert cable and connect according to Fig. 4 / Fig. 5.
- The union nut must be tightened to a torque of approx. 8 Nm (applies to Eltex grounding cable with a cable outer diameter of 8.6 mm). The seal must not be damaged.
- When using other cables or other cable diameters, the tightening torques must be determined by the user. The cable gland and the cap nut must be tightened firmly.
- Tightening the connection thread or the union nut too loosely or too tightly can impair the type of protection, the tightness and the strain relief.

The connecting lead of the ground contactor is routed in via the cable gland with kink guard (1, Fig. 4 / Fig. 5). Appliances for BIG-BAG grounding have two contactors, and the second lead is routed in via an additional cable gland with kink guard (3, Fig. 5).

A two-core cable for connecting the ground circuit with the PAL bonding lead is routed into the connecting terminal space via the cable inlet (2, Fig. 4 / Fig. 5). The double routing ensures that any disruptions to the PAL bonding lead are identified.



Note:

The two PAL leads belong to the intrinsically safe circuit, see cable entry 2, Fig. 4 / Fig. 5. The terminals of the Terrabox TCB030 are also marked as intrinsically safe terminals (blue).

This is **NO** protective ground link, the leads must **NOT** be coloured green/ yellow resp. yellow. The PAL connection can be made with a two-wire sheathed cable, with no wire colours prescribed, i.e., all colours apart from green/yellow resp. yellow are permitted.

The sheathed cable can be made in light blue. As the connecting terminals are already marked in blue, there is no absolute necessity for this.



A potential equalization system (PA) has to be set up along the complete measuring circuit.

The signal leads are routed via the cable inlets (4 and 5, Fig. 4 / Fig. 5), the supply voltage lead is routed in via the cable inlet (6, Fig. 4 / Fig. 5).



The maximum cable length in the intrinsically safe circuit must not exceed the maximum rated capacity and inductance (see Technical Specifications).

The device must always be connected to an equipotential bond.

In the ex factory state, the lead-ins (2, 4 and 5, Fig. 4 / Fig. 5) are sealed. Lead-ins not used must be blanked off.

Close the enclosure after completing the connections, making sure that the seals are seated properly. Do not damage the seals.

**Terrabox TCB030 connection example:
Cable rewriter 601KR/_ with clamp 70AG/70BG**

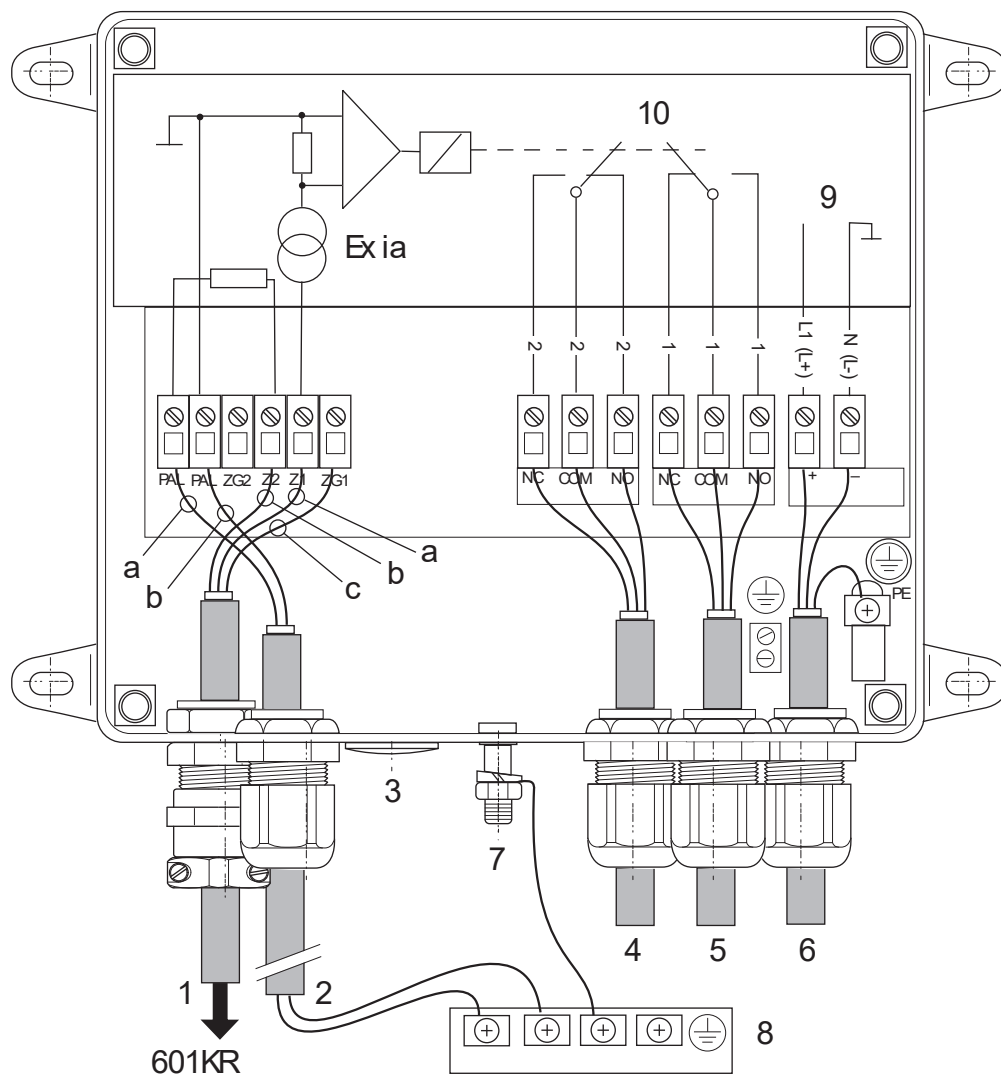

Fig. 4:
Connection
example:
active grounding
with
clamp 70AG/BG
via cable rewriter
601KR/_

- 1 Ground clamp supply lead
- 2 PAL connection (2 x 1,5mm²)
- 3 Blanking plug
- 4, 5 Signal contacts
- 6 Supply voltage lead
- 7 Ground terminal
- 8 Equipotential lead
- 9 Supply voltage 24 VDC or 115/230 VAC, see type plate
- 10 Contact position diagram: no enabling, indicator lamp red

core colors: a: blue b: brown c: green/yellow resp. yellow

z00033y

**Terrabox TCB030 connection example:
BIG-BAG grounding with two clamps 70HK**

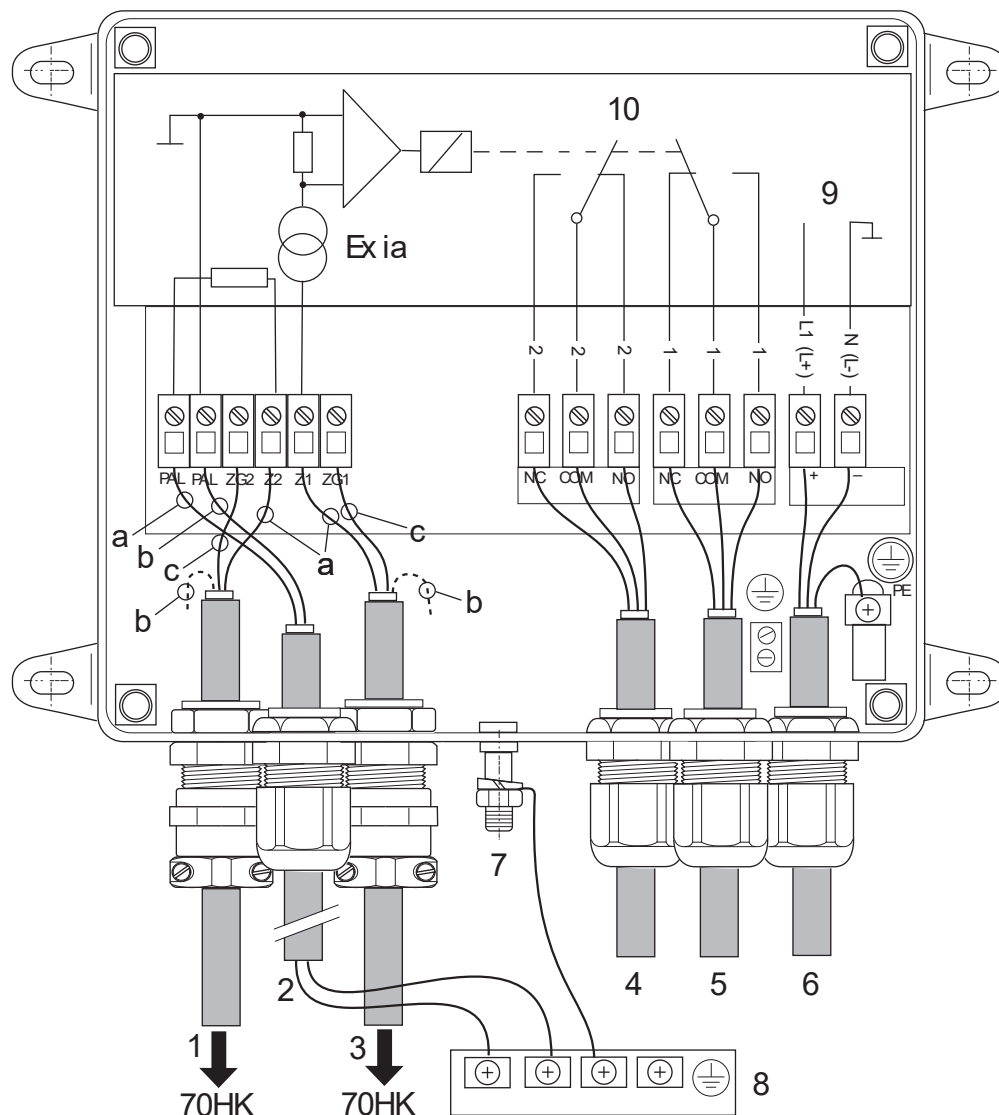

Fig. 5:
Connection
example:
BIG-BAG
grounding with two
clamps 70HK
(without cable
rewinder)

- 1 Ground clamp 2 supply lead
 - 2 PAL connection (2 x 1,5mm²)
 - 3 Ground clamp 1 supply lead
 - 4, 5 Signal contacts
 - 6 Supply voltage lead
 - 7 Ground terminal
 - 8 Equipotential lead
 - 9 Supply voltage 24 VDC or 115/230 VAC, see type plate
 - 10 Contact position diagram: no enabling, indicator lamp red
- core colors: a: blue b: brown c: green/yellow resp. yellow

z00035y

Terrabox TCB030 terminal assignment

Intrinsically safe terminal block (measurement circuit)	
Terminal	Connection - ground contact
PAL	Equipotential bond
PAL	Equipotential bond
ZG2	Clamp casing 2 (not assigned if 1 clamp only)
Z2	Clamp contact 2
Z1	Clamp contact 1
ZG1	Clamp casing 1
Non-intrinsically safe terminal block (contact circuit indicator signal)	
Terminal	Connection - relay contact
NC relay 2	Break contact 2
COM relay 2	Middle contact 2
NO relay 2	Make contact 2
NC relay 1	Break contact 1
COM relay 1	Middle contact 1
NO relay 1	Make contact 1
Connection - 24 V DC supply	
+	+ 24 V DC
-	0 V DC
Connection - 230 V AC supply	
1	230 V AC
N	0 V AC
Connection - 115 V AC supply	
1	115 V AC
N	0 V AC

Connection to the cable rewriter

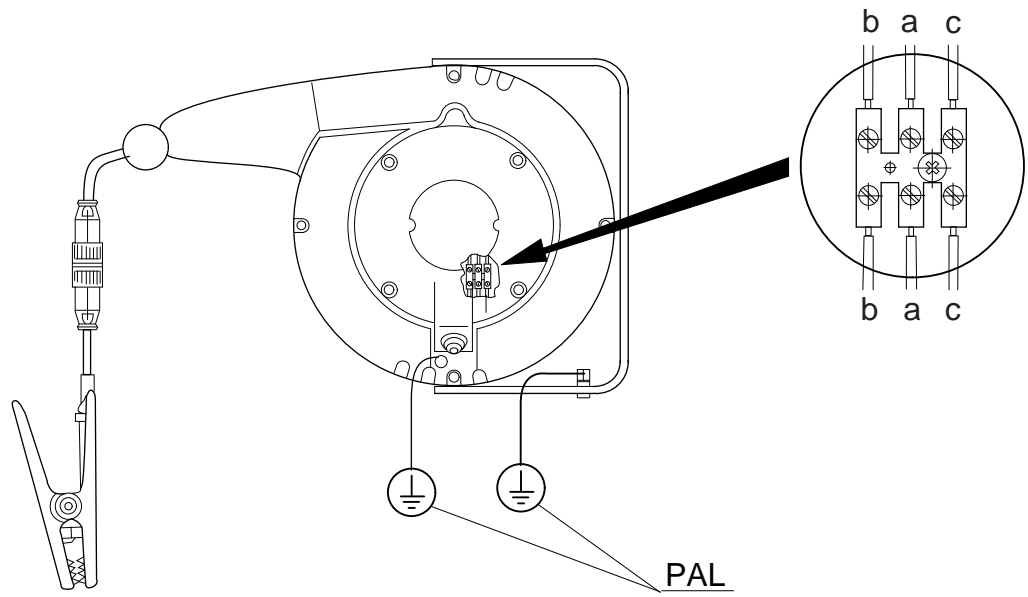
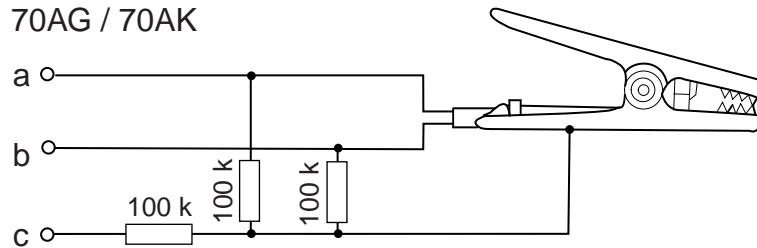

Fig. 6:
Connection of the
cable rewriter
601KR/_

z00034y

Connecting diagrams of the clamps

70AG / 70AK



70BG

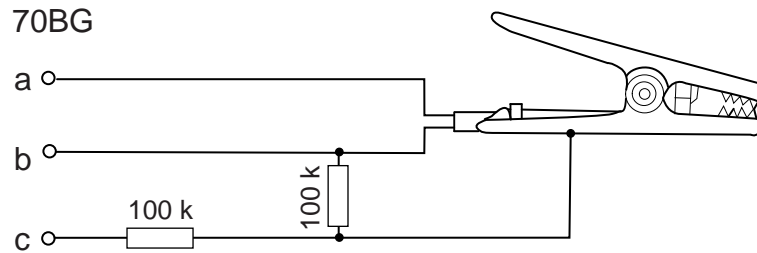

70HK

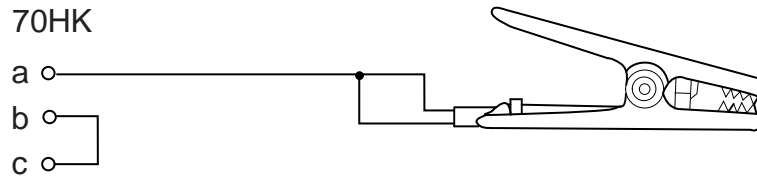

Fig. 7:
Connecting dia-
grams of the
clamps type 70AG,
70AK, 70BG and
70HK

Wire color: a blue b brown c green/yellow resp. yellow

z00036y

3.2 Terracompact II TCO030

3.2.1 Assembly



The Terracompact II TCO030 must be mounted outside the hazardous area. Only the intrinsically safe circuit is allowed to lead into the hazardous area.

The Terracompact II TCO030 is intended for assembly on a standard rail NS35. Several appliances may be plugged next to each other. Each Terracompact II unit is laid out for connection to a ground contact maker. The unit is preferably installed in the switchgear cabinet of a dry control room.

One power supply TCON01 (see spare parts) may be used to supply two Terracompact II with an operating voltage of 24 V DC.

3.2.2 Electrical connections



Warning!

The signal contact supply lead and the operating voltage supply leads must not be allowed to cross the intrinsically safe circuits (blue leads). Separate cable conduits must be provided for intrinsically safe circuits.



The maximum cable length in the intrinsically safe circuit must not exceed the maximum rated capacity and inductance (see Technical Specifications). A potential equalization system (PA) has to be set up along the complete measuring circuit. The device must always be connected to an equipotential bond.

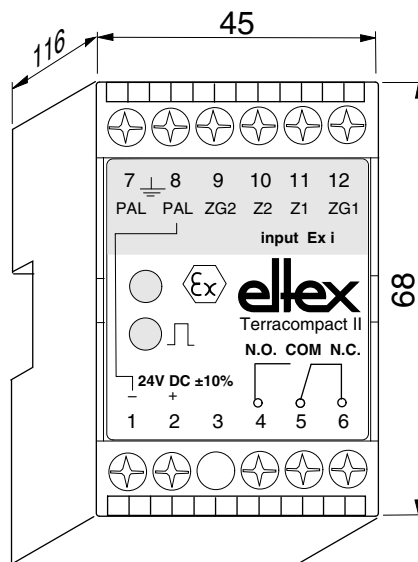

Fig. 8:
Terracompact II
TCO030 with ter-
minal assignment

Connect the intrinsically safe circuit, i.e. the ground contact makers or the cable rewriter, to terminals 9, 10, 11 and 12.

Connect the non-intrinsically safe circuits to terminals 1, 2, 3, 4, 5 and 6. The terminal assignment is shown in the following table.

The double equipotential lead PAL (Fig. 9, terminals 7 and 8) guarantees that disruptions of the PAL connection are identified.

Note:

The two PAL leads belong to the intrinsically safe circuit, see connection 7 and 8, Fig. 9. The terminals of the Terrabox TCB030 are also marked as intrinsically safe terminals (blue).

This is **NO** protective ground link, the leads must **NOT** be coloured green/yellow resp. yellow. The PAL connection can be made with a two-wire sheathed cable, with no wire colours prescribed, i.e., all colours apart from green/yellow resp. yellow are permitted.

The sheathed cable can be made in light blue. As the connecting terminals are already marked in blue, there is no absolute necessity for this.

Terracompact II TCO030 terminal assignment

Intrinsically safe terminal block (measurement circuit)	
Terminal	Connection - ground contact
7 and 8 (PAL)	Equipotential bonding of the plant (building)
9 (ZG2)	Clamp casing 2 (not assigned if 1 clamp only)
10 (Z2-)	Clamp contact 2
11 (Z1+)	Clamp contact 1
12 (ZG1)	Clamp casing 1
Non-intrinsically safe terminal block (contact circuit indicator signal)	
Terminal	Connection - relay contact
3	not assigned
4 (NO)	Make contact
5 (COM)	Middle contact
6 (NC)	Break contact
Connection - 24 V DC supply	
1 (-)	0 V DC
2 (+)	+24 V DC

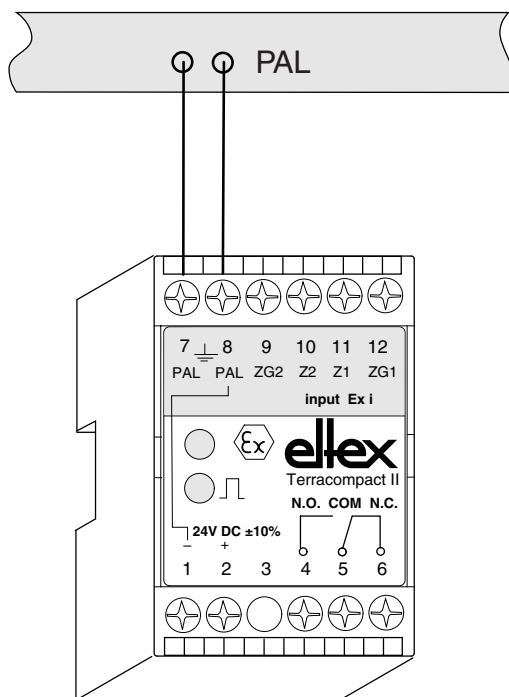

Fig. 9:
Connecting
the bonding
conductor PAL

Z00149y

**Terracompact II TCO030 connection example:
Cable rewriter 601KR/_ with clamp 70AG/70BG**

Connect the 601KR/_ cable rewriter to the TUE Terra-Control ground monitoring system in the terminal box of the cable rewriter (see Fig. 10). The cable rewriter must be linked permanently with the equipotential bonding lead.

Connect the ground clamp via a plug-type machine coupling and secure with a threaded joint (IP67).

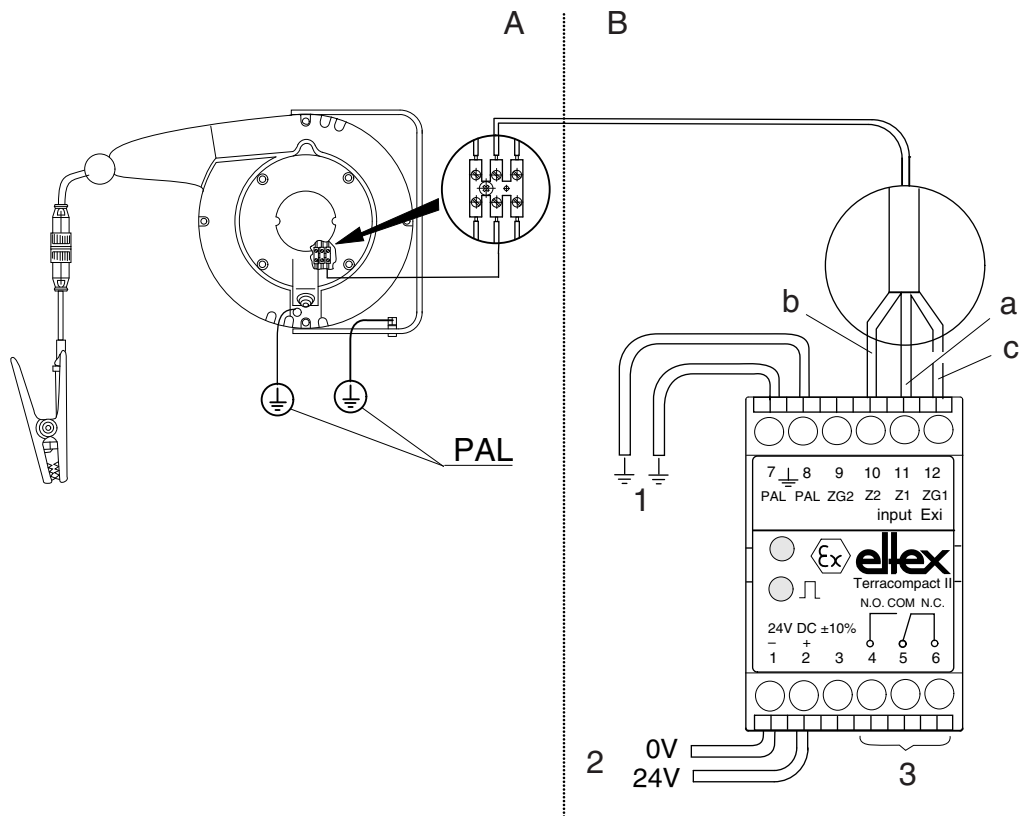

Fig. 10:
Connecting the
601KR/_ cable
rewinder to the
Terracompact II
TCO030

- A Explosive area
- B Safe area
- 1 Two fixed wiring terminals to PAL 1.5 mm²
- 2 To the DC power supply
- 3 Floating output
- a Blue cable
- b Brown cable
- c Green/yellow resp. yellow cable

**Terracompact II TCO030 connection example:
BIG-BAG grounding with two clamps 70HK**

The Eltex ground clamp 70HK is cut to length and terminated at the factory. Connect the clamp to the cable leading to the TUE Terra-Control ground monitoring system via a machine coupling (IP67), see Fig. 11.

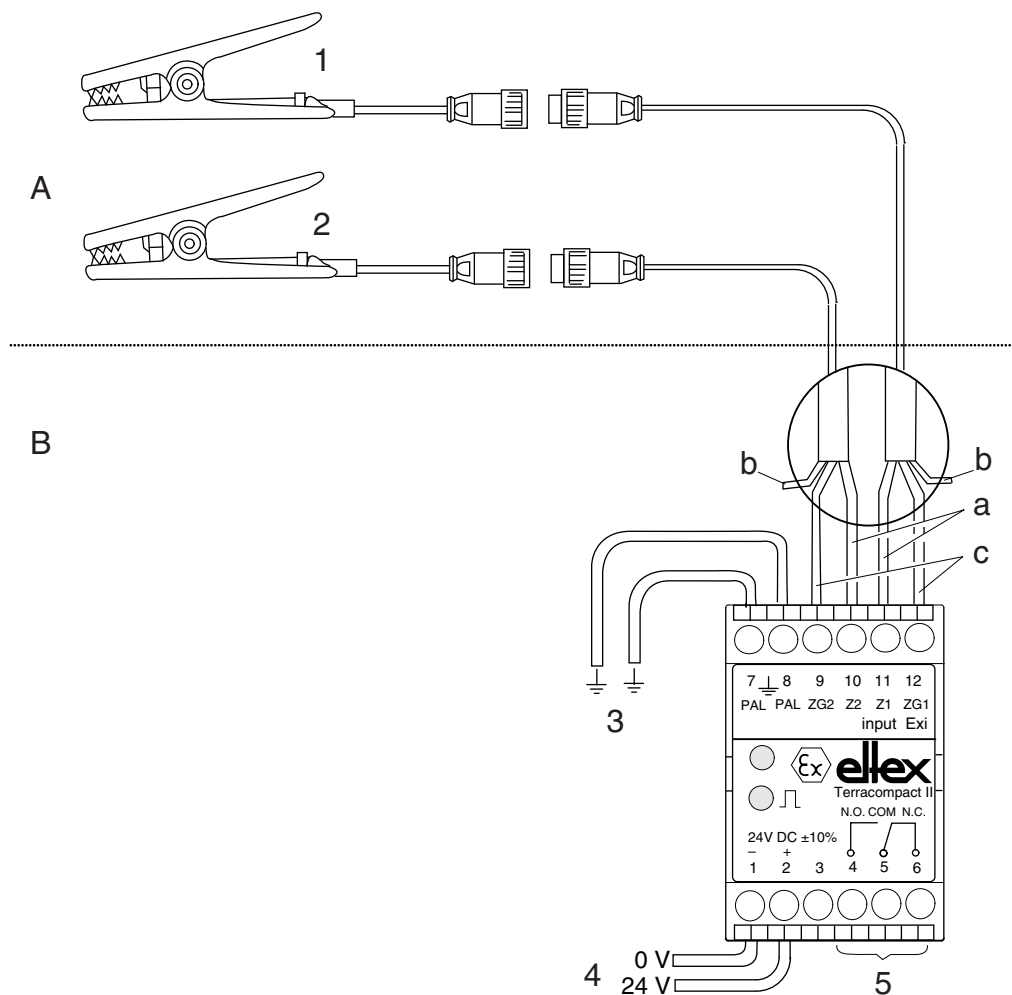

Fig. 11:
Connecting two
ground clamp
70HK for BIG-BAG
grounding to Ter-
racompact II
TCO030

- A Explosive area
- B Safe area
- 1 Clamp 1 (e.g. 70HK)
- 2 Clamp 2 (e.g. 70 HK)
- 3 Two fixed wiring terminals to PAL 1.5 mm²
(Part of the intrinsically safe circuit, green/yellow resp. yellow
wire colour is not permitted)
- 4 To the DC power supply
- 5 Floating output

wire color: a: blue b: brown, not connected c: green/yellow resp. yellow

3.2.3 Power supply TCON01

If no 24 V DC internal works connection is available, use the TCON01 power supply. The power supply is designed for mounting on standard rails NS35 and is capable of supplying two Terracompact II TCO030 units.

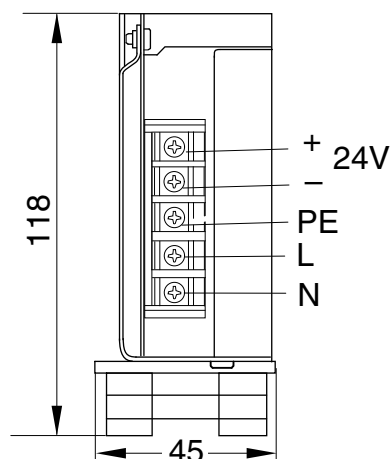

Fig. 12:
Terminal
assignment,
power supply
TCON01

Z00145y



3.3 Supply voltage

Depending on design, the units are intended for connection to 24 V direct voltage or 115 V / 230 V alternating voltage. The supply voltage is shown on the type plate. Subsequent changes cannot be made.

If a TCO30 or TCB030 is supplied with 24 V, make sure that the supply (24 V) is ungrounded. If required, the negative connection can be connected with PAL.

3.4 Cable specification

Cable into Ex zone:

three-core 3 x 1.5 mm²

core colors blue, brown, green/yellow resp. yellow, light blue-sheathed, oil and gasoline resistant.



Attention!

If the ground cable is subjected to tensile stress in the application (e.g. if KG/BN_ (ground cable) or KG/BS_ (helix ground cable) is used), the cable must be secured additionally with an external strain relief (e.g. a strap clip).

4. Operation



Caution!

Please note the type plate indicating the connection data (supply voltage) of the units.



Electrical systems used in explosion hazard areas must at all times be in a technically faultless condition. Any defects must be repaired or remedied immediately.

4.1 Start-up

If all connections (supply voltage, ground clamps, etc.) have been made correctly, the system is operational and the supply voltage may be activated.

4.2 Function

If the ground clamp has been connected properly and clamped to the container/ bin to be grounded and monitored, the intrinsically safe circuit is closed.

This status is indicated by the green light of the lamp and the relay contacts pick up at the same time. Using the relay, pumps or primary detectors may now be switched on or off. Interruptions or breaks in the ground link are indicated by the red light and the relays dropping at the same time. Any sensor contacts or conveyors switched via the relays will be switched off.

The diagram of the TUE30 ground monitoring system is shown in Fig. 13. Operating points see chapter 7 Technical specifications.

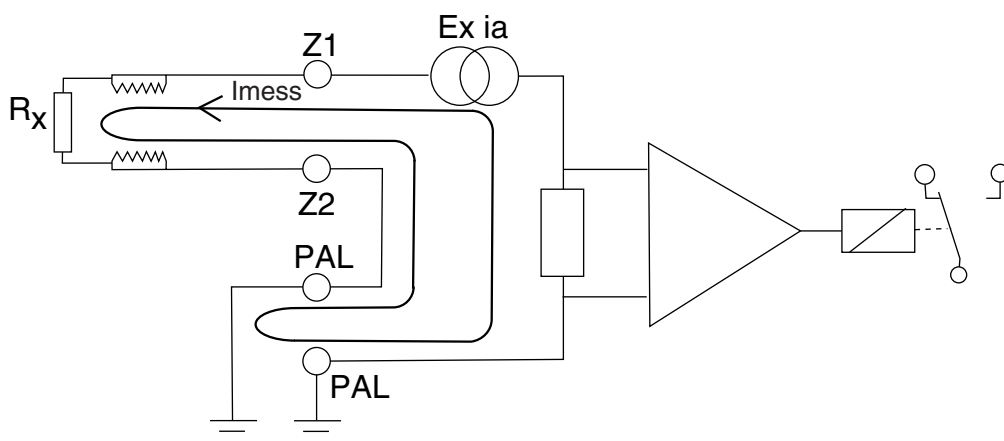

Fig. 13:
Diagram of the
TUE ground
monitoring system

R_z is the resistance between clamp 1 and PAL 2, i.e. R_x plus any resistance occurring between the PAL terminals;
 I_{mess} = intrinsically safe measuring circuit



4.3 Operation with 2 ground contactors, BIG-BAG grounding

During operation with 2 ground contactors, it is not only the ground link of the BIG-BAG which is being monitored, but also the conductivity of the BIG-BAG. Note that both ground contactors are connected to two different grounding points of the BIG-BAG. The intrinsically safe measuring current of the ground monitoring system flows from clamp 1 through the fabric of the BIG-BAG, with the conductivity of the BIG-BAG to be grounded being monitored at the same time. In this operating mode, ground contactor 1 is connected to the measuring current source, while ground contactor 2 is connected to ground potential.

Operating mode:

4.3.1 Before connecting the two ground contactors, the BIG-BAG has no connection to ground potential

The connection is made after both ground contactors have been connected to the grounding clips of the BIG-BAG. The intrinsically safe measuring current flows from ground contactor 1 through the BIG-BAG fabric to ground contactor 2, and via ground contactor 2 to ground potential.

4.3.2 Before connecting the two ground contactors, the BIG-BAG is already connected to ground potential

The connection is made as soon as ground contactor 1 is connected to the BIG-BAG. The intrinsically safe measuring current flows from ground contactor 1 through the fabric of the BIG-BAG via the existing ground contact to ground potential. A ground link of the BIG-BAG also exists in this case, with the effect that filling can proceed without hazard in this case. The interruption of the existing ground link results in the interruption of the intrinsically safe circuit, and filling would stop. For safety reasons, both ground contactors should always be connected because no assurance can be given that an existing ground link can be upheld throughout the entire filling process.

It makes sense in this case to specify in an appropriate work instruction to first connect ground contactor 2 and then ground contactor 1. The connection is therefore made only after both ground contactors have been connected.

4.4 Switching states of the relays in overview (Contact circuit indicator signal)

TCB030

	Relay 1			Relay 2		
	NC 1	COM 1	NO 1	NC 2	COM 2	NO 2
No supply voltage	●	●		●	●	
Contacteur open	●	●			●	●
Contacteur closed		●	●	●	●	

Both relays are controlled in opposition. This allows any absent supply voltage at the Terrabox to be distinguished from the switching states during operation.

TCO030

	Relay		
	NC 1	COM 1	NO 1
No supply voltage	●	●	
Contacteur open	●	●	
Contacteur closed		●	●

4.5 Function control

If the 70AG, 70BG and 70AK ground clamps are connected to a conductive, non-grounded object, the green operating light signals the enable state and the proper function.

Both clamps are connected when using the 70HK ground clamp; the green operating light also signals the enable state and the proper function.

5. Maintenance



Before carrying out maintenance or service work in the explosion hazard area, make sure that there is no potentially explosive atmosphere in the working zone.



Warning!

Maintenance and repair work must be carried out only by qualified electricians.

Cables and clamps must not be damaged. Damaged cables and clamps must be replaced with new parts.



5.1 Ground control units

Check the units at regular intervals for proper function, in doing so check the operating points and the earthing resistance. The intervals for the control are to be specified according to the application and therefore, depending on the operating conditions, by the operator. No other maintenance work is required.

Checking the operating points

Determine the operating points (see chapter 7 Technical specifications) by using a decimal resistor.

Eltex recommends carrying out the test with a suitable test device. The Eltex **TERRATEST** function testing device can be used for this purpose.



5.2 Ground contactors

To make sure that the proper ground connection exists with the equipotential bonding and that no malfunctions occur in active contactors, the ground contactor must be cleaned when dirty.

Store the ground contactor such that it cannot be damaged. Replace damaged cables and contactors with new parts. Whenever possible, the ground contactor should either be hung up freely or be clamped to a non-conductive object.

Checking the resistance to earth for passive clamps

Measurement of the earthing resistance between clamp jaw and ground (PAL):

ground clamp 70SG or 70PG:

earthing resistance: 235 kOhm \pm 5 %

clamping force: 140 N \pm 20 %

ground clamp 70OK or 70PK:

earthing resistance: <1 Ohm

clamping force: 100 N \pm 20 %



5.3 Cable rewinders

Perform regular checks to ensure that the cable and the insulation show no tears or abrasion that could impair the cable's insulation or functioning. Clean the cable with a cloth soaked in warm water to remove dirt or incrustations and ensure perfect unwinding.

Defective devices must be sent in for repair.

6. Troubleshooting



Before carrying out maintenance or service work in the explosion hazard area, make sure that there is no potentially explosive atmosphere in the working zone.



Warning!

Maintenance and repair work must be carried out only by qualified electricians.

Error/Symptom	Remedy
Terra-Control unit enabled, although the ground clamp has not been clamped to a conductive object.	Dirt settled on ground clamp: Clean ground clamp with solvent (cleaning gasoline). Do not immerse the plug of the coupling in solvent.
Unit enabled after attaching the clamp to a conductive and grounded object, although the connections to terminals Z2 and/or PAL are disrupted.	No error! The unit identifies the ground connection of the object and enables.
Unit fails to enable, cable ripped from the plug or from the clamp.	Shorten cable and reconnect (see Electrical Connections)
Cable break on the rewind reel.	Shorten cable and reconnect (see Electrical Connections).

7. Technical specifications

7.1 Terrabox TCB030

Safety-related parameters

	MTTFd: [years] (0.5 A relay load)	MTTFd: [years] (5 A relay load)
1 switching cycle / day	2457.2	252.2
10 switching cycles / week	814.2	27.2

as shown on
appliance
marking:

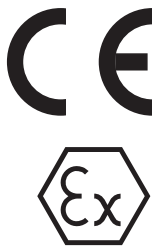



Supply voltage*	TCB030/_0: 24 (21...31) V DC, 100 mA TCB030/_1: 115 (105...125) V AC 50/60 Hz, 100 mA TCB030/_2: 230 (210...250) V AC 50/60 Hz, 50 mA maximum voltage for safety reasons $U_m = 250$ V
Operating ambient temperature	-20...+70 °C (-4...+158 °F)
Storage temperature	-20...+80 °C (-4...+176 °F)
Ambient humidity	max. 80 % r.h., non-dewing BIG-BAG design: max. 70 % r.h.
Enclosure material	sheet metal steel with wall bracket, enameled
Protection class	IP64, EN 60529
Dimensions	211 x 211 x 123 mm (H x W x D), (see Fig. 14)
Weight	approx. 5 kg
Indicator signal (Contact circuit)	2 floating changeover contacts load capacity: $U \leq 230$ V, $I \leq 5$ A, $P \leq 100$ VA maximum voltage for safety reasons $U_m = 250$ V switching action signalled via green/red LED
Measurement circuit	intrinsically safe, EN 60079-11 maximum voltage U_0 : 35 V maximum current I_0 : 1,5 mA maximum output P_0 : 13 mW maximum permissible connected load capacity / inductance: C_0/L_0 : 37nF/50mH or 45nF/2mH linear characteristic
Operating points	Standard TCB030/S_ ON <20 kOhm, OFF >50 kOhm ± 20 % BIG-BAG TCB030/B_ ON <50 MOhm, OFF >100 MOhm ± 20 % BIG-BAG TCB030/2_ ON <50 MOhm, OFF >100 MOhm ± 20 %
Approval / Marking	ATEX: PTB 00 ATEX 2174 X II 2(1) G Ex eb mb [ia Ga] IIC T5 Gb II 2(1) D Ex tb [ia Da] IIIC T100°C Db

* **Note!** The device will be damaged if the maximum supply voltage is exceeded. The safety of the intrinsically safe measuring circuit is guaranteed up to the specified maximum supply voltage.

7.2 Terracompact II TCO030

Safety-related parameters

	MTTFd: [years] (5 A relay load)
1 switching cycle / day	258.3
1 switching cycle / week	1347.7

Supply voltage*	24 (21...31) V DC maximum voltage for safety reasons: $U_m = 250$ V
Power input	I_B typical 80 mA
Operating ambient temperature	-20...+70 °C (-4...+158 °F)
Ambient humidity	max. 70 % r.h., non-dewing
Design	standard enclosure for installation on standard rail NS35
Protection class	enclosure IP40, (terminals IP10)
Dimensions	68 x 45 x 116 mm (H x W x D)
Weight	approx. 200 g
Assembly	assembly on standard rail NS35, path height 15 mm; outside explosion hazard area
Connection	screw-type terminals, connecting diameter 1,5 mm ²
Indicator signal	potential-free changeover contact load capacity: $U \leq 230$ V, $I \leq 5$ A, $P \leq 100$ VA maximum voltage for safety reasons: $U_m = 250$ V switching action signalled via green/red LED in front plate
Measurement circuit	intrinsically safe, EN 60079-11 maximum voltage U_0 : 35 V maximum current I_0 : 1,5 mA maximum power rating P_0 : 13 mW maximum permissible connected load capacity / inductance: C_0/L_0 : 37nF / 50mH or 45nF / 2mH, linear characteristic
Operating points	TCO030S: On <20 kW, Off >50 kW ± 20 % TCO030B: On <50 MW, Off >100 MW ± 20 %
Marking	 II (1) G [Ex ia Ga] IIC  II (1) D [Ex ia Da] IIIC
Approval	PTB 99 ATEX 2188 X

as shown on
appliance
marking:



* Note!

The device will be damaged if the maximum supply voltage is exceeded. The safety of the intrinsically safe measuring circuit is guaranteed up to the specified maximum supply voltage.

7.3 Power supply TCON01



Input voltage	85...265 V AC 50/60 Hz
Output voltage	24 V DC
Output current	max. 0.2 A
Operating ambient temperature	0...+60 °C (+32...+140 °F)
Storage temperature	-20...+85 °C (-4...+185 °F)
Ambient humidity	max. 70 % r.h., non-dewing
Enclosure/Mounting	standard Enclosure, on standard rail NS35
Protection class	IP20
Dimensions	118 x 45 x 107 mm (H x W x D)
Connection	screw terminals

8. Dimensions

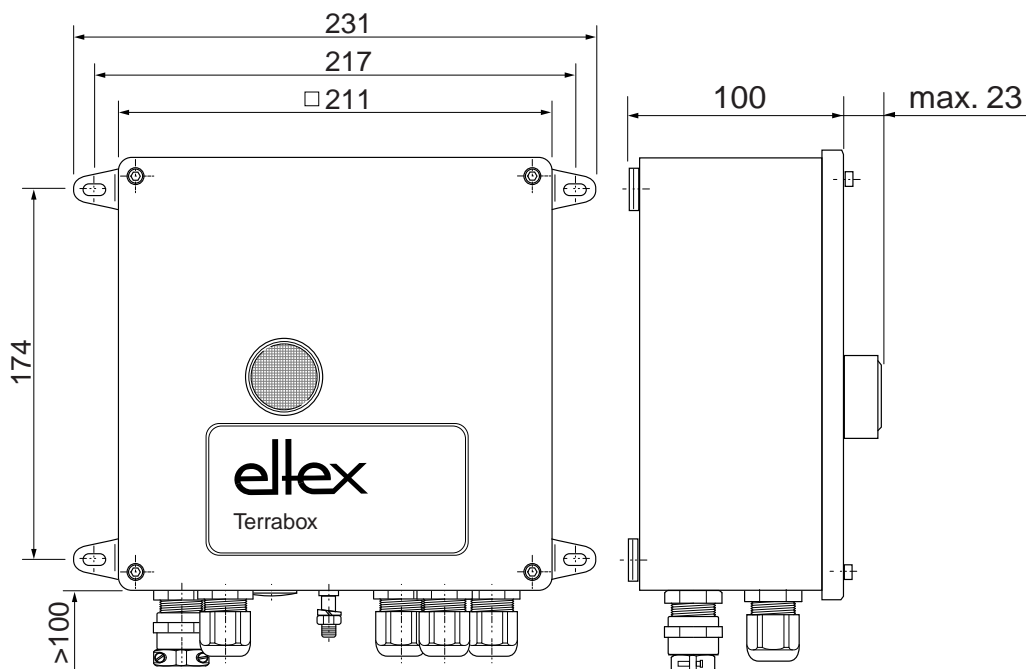

Fig. 14:
Dimension
Terrabox TCB030

Z00032y + Z00038y

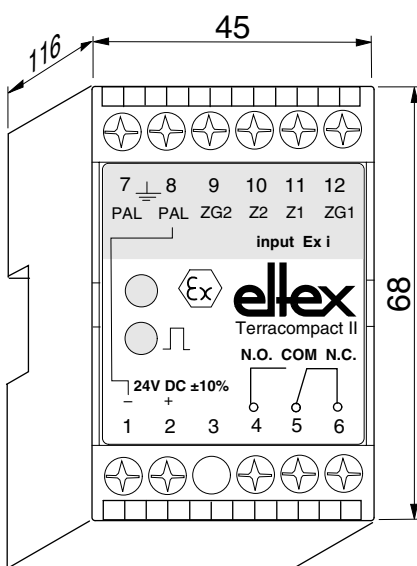

Fig. 15:
Dimension
Terracompact II
TCO030

Z00148y

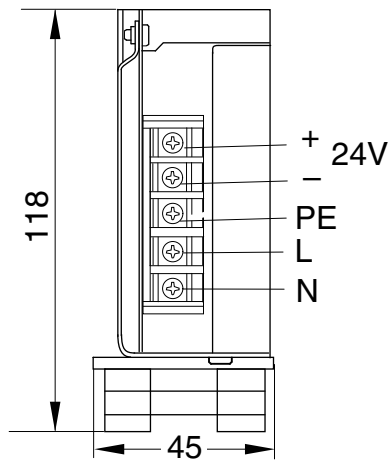

Fig. 16:
Dimension power
supply TCON01
(Deep: 107 mm)

Z00145y

9. Accessories and spare parts

Article	Article No.
TERRATEST Function testing device	TERRA-TU
Power supply for max. 2 TCO030, 100...240 V AC	TCON01
Indicator light actuator, white with fixing nut (for TCB030)	102670
Cable gland with kink guard Ex e, M20 x 1.5, black, without fixing nut (for TCB030)	102671
Cable gland Ex e, M20 x 1.5, black, without fixing nut (for TCB030)	103681
Cable gland Ex e, M20 x 1.5, black/blue, without fixing nut (for TCB030)	102672
Blanking plug Ex e, M20 x 1.5 for cable gland, red (for TCB030)	102675
Blanking plug Ex e, M20 x 1.5 for enclosure (instead of cable gland), black (for TCB030)	102676
Fixing nut M20 x 1.5, black (for TCB030)	102674
Clamp holder	113112
Clamp holder, wall mounting	116740
Active ground clamp, large with IP67 coupling plug and 300 mm ± 50mm lead length or without plug and lead length as specified (3, 6, 9, 12, 15 or 18 m) or without plug and helix lead length as specified (5 or 10 m)	70AG
Active ground clamp, large, for BIG-BAG grounding with IP67 coupling plug and 300 mm ± 50mm lead length or without plug and lead length as specified (3, 6, 9, 12, 15 or 18 m) or without plug and helix lead length as specified (5 or 10 m)	70BG
Active ground clamp, small with IP67 coupling plug and 300 mm ± 50mm lead length or without plug and lead length as specified (3, 6, 9, 12, 15 or 18 m) or without plug and helix lead length as specified (5 or 10 m)	70AK
Active ground clamp, small, for BIG-BAG grounding with IP67 coupling plug and 300 mm ± 50mm lead length or without plug and lead length as specified (3, 6, 9, 12, 15 or 18 m) or without plug and helix lead length as specified (5 or 10 m)	70HK

Article	Article No.
Active ground clamp TERRA-C standarf	TERRA-C/SO
Active ground clamp TERRA-C BIG-BAG	TERRA-C/BO
Cable rewriter, aluminum, with 3.0 m connecting lead and max. 20 meters ground cable with IP67 coupling socket to connect ground contactors with plugs	601KR/AW
Cable rewriter, aluminum, with 3.0 m connecting lead and max. 12 meters ground cable with IP67 coupling socket to connect ground contactors with plugs	601KR/DW
Cable rewriter, plastic, with 3.0 m connecting lead and max. 9 meters ground cable with IP67 coupling socket to connect ground contactors with plugs	601KR/KW
Active helix ground cable, 3-pin with wire end sleeve and IP67 coupling socket for connecting ground contactors, extensible 1 to 5 m, cable color: light blue	KG/BSAB050
Active helix ground cable, 3-pin with wire end sleeve and IP67 coupling socket for connecting ground contactors, extensible 2 to 10 m, cable color: light blue	KG/BSAB100
Active helix ground cable, 3-pin with coupling plug and IP67 coupling socket for connecting ground contactors, extensible 1 to 5 m, cable color: light blue	KG/BSBS050
Active helix ground cable, 3-pin with coupling plug and IP67 coupling socket for connecting ground contactors, extensible 2 to 10 m, cable color: light blue	KG/BSBS100
Active ground cable, 3-pin with wire end sleeve and IP67 coupling socket for connecting ground contactors, 5 to 95 m in steps to 5 meters (specify length) cable color: light blue	KG/BNAB____
Active ground cable, 3-pin with coupling plug and IP67 coupling socket for connecting ground contactors, 5 to 95 m in steps to 5 meters (specify length) cable color: light blue	KG/BNBS____
3-pin ground cable (specify length)	LEI00009
4-pin coupling socket, IP67 (side: cable rewriter)	ELM00714
4-pin coupling plug, IP67 (side: contactor)	ELM00713
Operating Instructions	BA-en-4003

Please specify the article number when ordering.

A. Annex

A.1 Grounding without ground monitoring unit (active grounding)

In compliance with EC-Type Examination Certificate PTB18ATEX2005 (**TERRALIGHT**), PTB99ATEX2188X (TCO) and PTB00ATEX2174X (TCB), the clamps and cable rewinders may be used in the potentially explosive zone with the following intrinsically safe ground monitoring units:

- **TERRALIGHT** Typ TERRA-L/____
- Terracompact II Type TCO030S and TCO030B
- Terrabox Type TCB030/____
- or other ground monitoring systems with the following max. output values:

voltage:	U_o	≤ 40 V DC
current strength:	I_o	≤ 250 mA
power:	P_o	≤ 650 mW

The following Eltex clamps have been specially tested for the potentially explosive zone and carry the EC-Type Examination Certificate DMT00ATEXE068X and BVS 20 ATEX E 017 X:

- Clamps Type TERRA-C/SO and TERRA-C/BO
- Clamps Type 70AG, 70AK, 70BG, 70HK
- Cable rewinders Type 601KR/AW, 601KR/DW, 601KR/KW

The maximum connectable total cable length to the grounding systems Terra-Control TUE30 resp. **TERRALIGHT** is 200 m.

Please note the information in the separate operating instructions for the Eltex ground clamps series 70 and **TERRACLAMP** as well as series 601KR cable rewinders.

A.2 Grounding without ground monitoring unit (passive grounding)

Ground clamps (Zone 0, 1, 2, 20, 21, 22):

The Eltex ground clamps Type 70OK, 70PK, 70SG, 70PG are approved in compliance with EC-Type Examination Certificate EPS19ATEX1184X.

Cable rewinders (Zone 1, 2, 21, 22):

The Eltex cable rewinders Type 601KR/CW and 601KR/EW may be classified as non-electrical devices in compliance with RL 2014/34/EU and are therefore not subject to certification by a notified body. Instead, they can be internally certified under the conformity evaluation procedure. This is done by Eltex, and Eltex confirm with the declaration of conformity that the units comply with the appropriate directives, norms and standards. The technical documentation must be deposited with a notified body, but it does not need to be tested and reviewed by that body. Eltex has deposited the data with the PTB under number 05ATEXD121-1.

A.3 Overview Approvals

Approval No.	Units	File name
PTB99ATEX2188X	Terracompact II Type TCO030S, TCO030B	TCO030-ATEX-en.pdf
PTB00ATEX2174X	Terrabox Type TCB030/___	TCB030-ATEX-en.pdf
BVS 20 ATEX E 017 X	Clamps Type TERRA-C/SO, TERRA-C/SL, TERRA-C/BO, TERRA-C/BL	TERRA-C-Clamp- ATEX-en.pdf
DMT00ATEXE068X	Clamps Type 70AG, 70AK, 70BG, 70HK Cable rewinders Type 601KR/AW, 601KR/DW, 601KR/KW	601KR+Zangen 70- aktiv-ATEX-en.pdf
EPS19ATEX1184X	Clamps Type 70OK, 70PK, 70SG, 70PG	70-Zangen-passiv- ATEX-en.pdf
PTB 05ATEXD121-1	Cable rewinders Type 601KR/BW, 601KR/CW, 601KR/EW	601KR-passiv-Selbst- bescheinigung.pdf
IECEX BVS 20.0012 X	Clamps Type TERRA-C/SO, TERRA-C/SL, TERRA-C/BO, TERRA-C/BL	TERRA-C- IECEX_BVS_20001x_ en.pdf
IECEX BVS 16.0016X	Clamps 70** Cable rewinders 601KR/*W	601KR+Zangen 70- IECEX_BVS_160016x_ en.pdf

EU-Declaration of Conformity

CE-4003-en-2411_TCB



Eltex-Elektrostatik-Gesellschaft mbH
Blauenstraße 67 - 69
D-79576 Weil am Rhein



declares in its sole responsibility that the product

TERRABOX TCB030 Ground Monitoring Device (according to Eltex reference code)

Identification:  II 2(1) G Ex eb mb [ia Ga] IIC T5 Gb and II 2(1) D Ex tb [ia Da] IIIC T100°C Db
Certification-no. PTB 00 ATEX 2174 X, edition 1 issued 11/07/2017
Notified body: Physikalisch-Technische Bundesanstalt, Bundesallee 100, 38116 Braunschweig, NB No. 0102

complies with the following directives and standards.

Relevant EU-Directive:

2014/34/EU

Directive: Equipment or Protective System intended for use in potentially explosive Atmospheres

Harmonized standards applied:

EN IEC 60079-0:2018	Explosive atmospheres – Equipment – General requirements
EN IEC 60079-7:2015 + A1:2018	Explosive atmospheres – Equipment protection by increased safety "e"
EN 60079-11:2012	Explosive atmospheres – Equipment protection by intrinsic safety "i"
EN 60079-18:2015 + A1:2017	Explosive atmospheres – Equipment protection by encapsulation "m"
EN 60079-31:2014	Explosive atmospheres – Equipment dust ignition protection by enclosure "t"

Relevant EU-Directive:

2014/35/EU

Low Voltage Directive

Harmonized standard applied:

EN 60204-1:2018	Safety of machinery – Electrical equipment of machines – General requirements
-----------------	---

Relevant EU-Directive:

2014/30/EU

EMC Directive

Harmonized standards applied:

EN 55011:2016 + A1:2017 + A11:2020 + A2:2021	Industrial, scientific and medical equipment – Radio-frequency disturbance characteristics – Limits and methods of measurement
EN IEC 61000-3-2:2019 + A11:2021	Electromagnetic compatibility (EMC) – Limits – Limits for harmonic current emissions (equipment input current ≤ 16 A per phase)
EN 61000-3-3:2013 + A1:2019 + A2:2011 + A2:2011/AC:2022	Electromagnetic compatibility (EMC) – Limits – Limitation of voltage changes, voltage fluctuations and flicker in public low-voltage supply systems, for equipment with rated current ≤ 16 A per phase and not subject to conditional connection
EN IEC 61000-6-2:2019	Electromagnetic compatibility (EMC) – Generic standards – Immunity for industrial environments

Relevant EU-Directives:

2011/65/EU
(EU) 2015/863

RoHS Directive
RoHS Delegated Directive

in the version effective at the time of delivery.

Eltex-Elektrostatik-Gesellschaft mbH keep the following documents for inspection:

- proper operating instructions
- plans
- other technical documentation

Weil am Rhein, 05.11.2024
Place/Date



Lukas Hahne, Managing Director

EU-Declaration of Conformity

CE-4003-en-2411_TCO

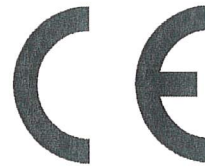

Eltex-Elektrostatik-Gesellschaft mbH
Blauenstraße 67 - 69
D-79576 Weil am Rhein



declares in its sole responsibility that the product

Terrakompakt TCO030 S / B Ground Monitoring Device

Identification:  II (1) G [Ex ia Ga] IIC and II (1) D [Ex ia Da] IIIC
Certification-no.: PTB 99 ATEX 2188 X
Notified body: Physikalisch-Technische Bundesanstalt, Bundesallee 100, 38116 Braunschweig, NB No. 0102

complies with the following directives and standards.

Relevant EU-Directive:

2014/34/EU

Directive: Equipment or Protective System intended for use in potentially explosive Atmospheres

Harmonized standards applied:

EN IEC 60079-0:2018

Explosive atmospheres – Equipment – General requirements

EN 60079-11:2012

Explosive atmospheres – Equipment protection by intrinsic safety "i"

Relevant EU-Directive:

2014/35/EU

Low Voltage Directive

Harmonized standard applied:

EN 60204-1:2018

Safety of machinery – Electrical equipment of machines – General requirements

Relevant EU-Directive:

2014/30/EU

EMC Directive

Harmonized standards applied:

EN 55011:2016 + A1:2017
+A11:2020 + A2:2021

Industrial, scientific and medical equipment – Radio-frequency disturbance characteristics – Limits and methods of measurement

EN IEC 61000-6-2:2019

Electromagnetic compatibility (EMC) – Generic standards – Immunity for industrial environments

Relevant EU-Directives:

2011/65/EU

RoHS Directive

(EU) 2015/863

RoHS Delegated Directive

in the version effective at the time of delivery.

Eltex-Elektrostatik-Gesellschaft mbH keep the following documents for inspection:

- proper operating instructions
- plans
- other technical documentation

Weil am Rhein, 05.11.2024
Place/Date

Lukas Hahne, Managing Director

Eltex offices and agencies

The addresses of all
Eltex agencies can be
found on our website at
www.eltex.de



z01007y



Eltex-Elektrostatik-Gesellschaft mbH
Blauenstraße 67-69
79576 Weil am Rhein | Germany
Phone +49 (0) 7621 7905-422
eMail info@eltex.de
Internet www.eltex.de