

# Operating Instructions

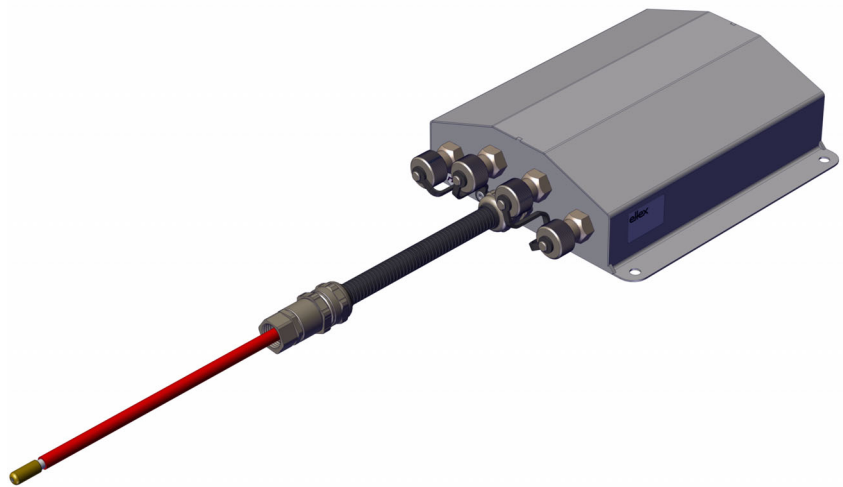

F01070y

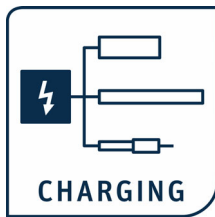

## Distributor PCV, PCV6 Extension cable KA

for DC operation

BA-en-3042-2501





# List of contents

<b>1</b>	<b>Overview Distributor PCV</b> .....	<b>6</b>
1.1	Distributor PCV (max. 30 kV) .....	6
1.1.1	Variants of the distributor PCV .....	6
1.2	Distributor PCV6 (max. 60 kV) .....	7
1.2.1	Variants of the distributor PCV6 .....	7
1.3	Overview extension cable KA/_Y .....	8
1.3.1	Variants of the extension cable KA/_Y .....	8
<b>2</b>	<b>Safety</b> .....	<b>9</b>
2.1	Proper use .....	9
2.2	Identification of risks and hazards .....	9
2.3	Work and operational safety .....	10
2.4	Technical advance .....	11
<b>3</b>	<b>Installation and assembly</b> .....	<b>12</b>
3.1	Assembly of the distributor .....	12
3.2	Selecting the charging bar .....	12
3.3	Connecting the high voltage cable .....	12
<b>4</b>	<b>Operation</b> .....	<b>14</b>
4.1	Startup .....	14
<b>5</b>	<b>Maintenance</b> .....	<b>15</b>
<b>6</b>	<b>Technical specifications PCV, PCV6 and extension cable KA</b> .....	<b>16</b>
<b>7</b>	<b>Dimensions</b> .....	<b>17</b>
7.1	Distributor PCV (max. 30 kV) .....	17
7.2	Distributor PCV6 (max. 60 kV) .....	19
7.3	Extension cable KA/YY_ _ _ (max. 30 kV) .....	20
<b>8</b>	<b>Spare parts and accessories</b> .....	<b>21</b>
	<b>Declaration of Conformity</b> .....	<b>22</b>
	<b>UKCA Conformity</b> .....	<b>23</b>



## Dear Customer,

The PCV and PCV6 distributors are designed for distributing high voltage power to the charging bars operated with DC voltage.

The number of components connectable to the POWER CHARGER high voltage generator can be increased via the PCV and PCV6 distributor. In case of larger distances between the generator and the bars, cable length and installation effort can be saved by placing the distributor closer to the bars.

The KA extension cable is used to connect bars with a short cable to a high voltage generator mounted further away.

The PCV and the PCV6 distributors feature the following characteristics:

- 4 plug-type high voltage outputs
- small dimensions
- easy installation
- robust design

Please read the operating instructions carefully before starting the instrument. This will help you prevent personal injuries and damage to property.

Please give us a call if you have any suggestions, proposals or ideas for improvements. We greatly appreciate the feedback from the users of our appliances.

# 1. Overview Distributor PCV

## 1.1 Distributor PCV (max. 30 kV)

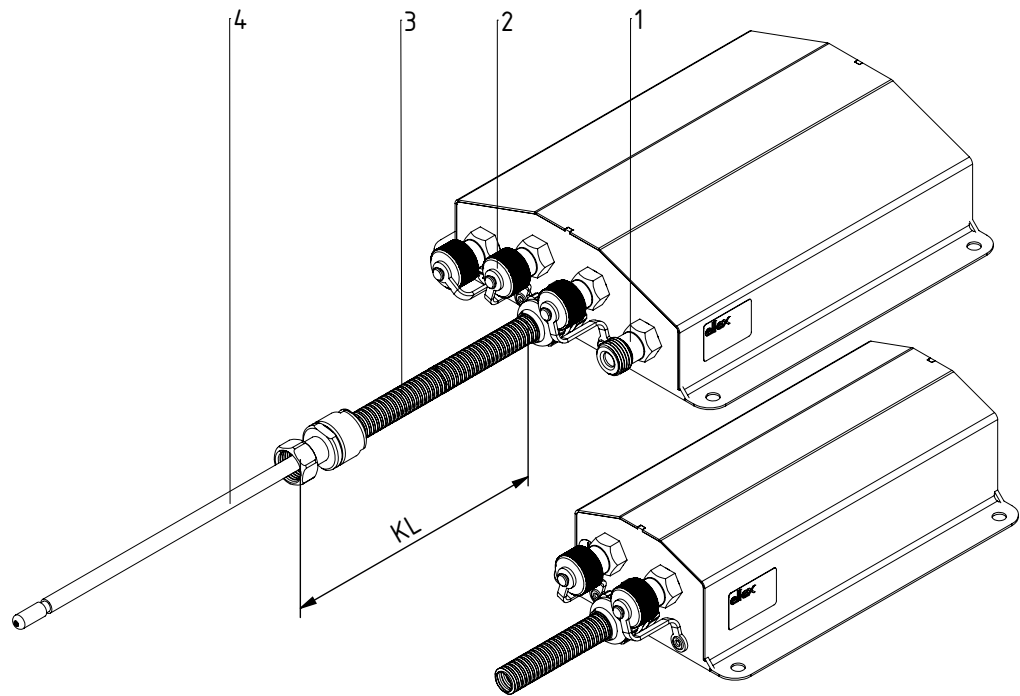

Fig. 1:  
Distributor PCV/4,  
PCV/2

Z-117457ey\_4

- 1 High voltage output (without sealing cap) for connection to a charging bar
- 2 Sealing cap
- 3 High voltage connection cable (cable length KL variable)
- 4 High voltage plug (design variant Y, for connection to a POWER CHARGER high voltage generator)

### 1.1.1 Variants of the distributor PCV

The PCV/4 variant with 4 high voltage outputs and the PCV/2 resp. PCV/Y variants with 2 high voltage outputs are available for connection to the POWER CHARGER high voltage generator (PCV/\_Y).

The distributor can also be connected to the Eltex KNH34, KNH35 and HSG61 series generators (PCV/\_R) in case of high voltage connection cable with corresponding high voltage plug.

The length of the fixed connected high voltage cable is variable between 5 and 350 dm in 5-dm-steps.

## 1.2 Distributor PCV6 (max. 60 kV)

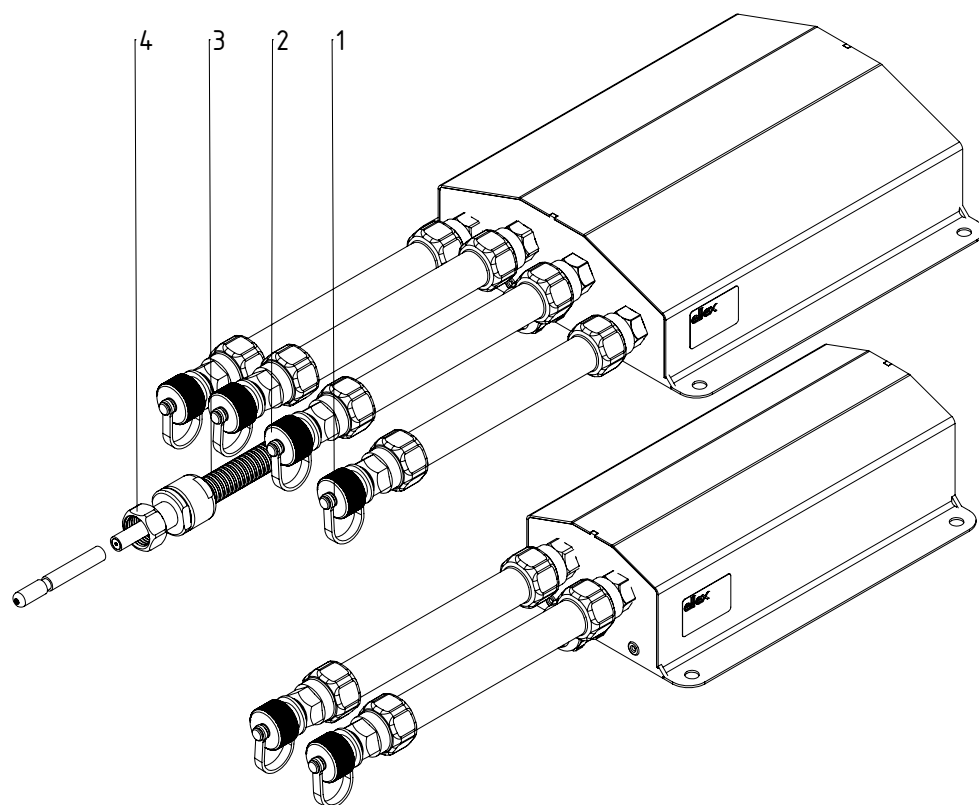

Fig. 2:  
Distributor  
PCV6/4, PCV6/2

- 1 High voltage output (without sealing cap) for connection to a charging bar
- 2 Sealing cap
- 3 High voltage connection cable (cable length variable)
- 4 High voltage plug (design variant X, for connection to a POWER CHARGER high voltage generator)

### 1.2.1 Variants of the distributor PCV6

The PCV6/2 variant with 2 high voltage outputs and the PCV6/4 variant with 4 high voltage outputs are available for connection to the POWER CHARGER high voltage generator (PCV6/\_X).

The distributor can also be connected to the Eltex KNH34, KNH35 and HSG61 series generators (PCV6/\_U) in case of high voltage connection cable with corresponding high voltage plug.

The length of the fixed connected high voltage cable is variable between 5 and 350 dm in 5-dm-steps.

Z-118054ay\_1

### 1.3 Overview extension cable KA/\_Y

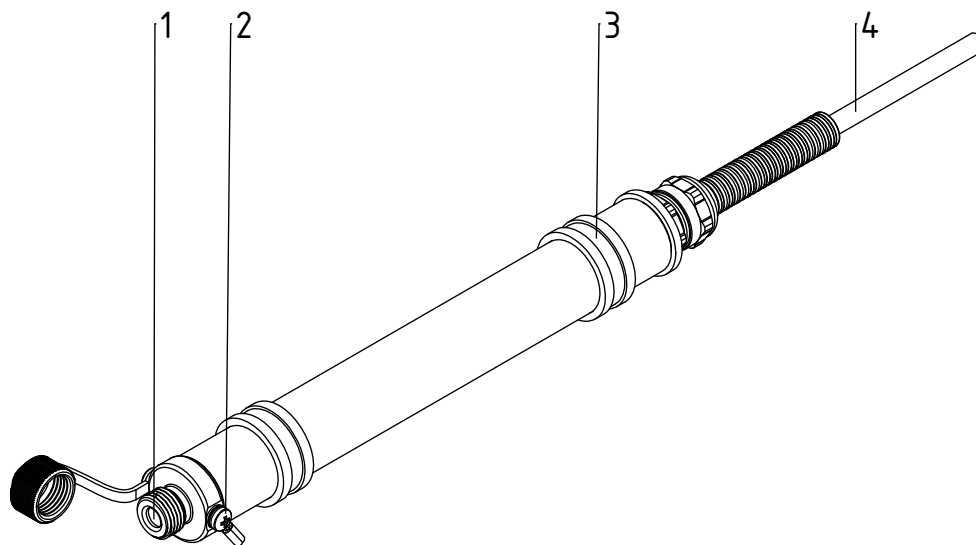

Fig. 3:  
Extension cable  
KA/\_Y

Z-117693b\_Y

- 1 Socket
- 2 Ground connection
- 3 Mounting clamp (2 x included in delivery)
- 4 High voltage cable Supply line

#### 1.3.1 Variants of the extension cable KA/\_Y

Various plug variants are available for connection to the high voltage generator.

- If you have selected the wiring of your electrode to the generator POWER CHARGER, we recommend to use the version KA/YY\_\_\_ (plug Y / socket Y, cable length 010 - 350 dm).
- If you use the KNH18 or KNH3x generator, we recommend to use the version KA/RY\_\_\_ (plug R / socket Y, cable length 010 - 350 dm).



## 2. Safety

The extension cable KA and the PCV and PCV6 distributors has been designed, built and tested using state-of-the-art engineering, and has left the factory in a technically and operationally safe condition. If used improperly, the units may nevertheless be hazardous to personnel and may cause injury or damage. Read the operating instructions carefully and observe the safety instructions.

Always observe the rules and regulations applying in your country with reference to opening and repairing electrical appliances.

The manufacturers will not assume any liability and warranty if the units are used improperly or used outside the intended purpose.

For warranty conditions, please refer to the General Terms and Conditions (GTC), see [www.eltex.de](http://www.eltex.de).

### 2.1 Proper use

The extension cable KA and the PCV and PCV6 distributors must be operated only in connection with the appropriate Eltex charging bars for DC operation and with the appropriate Eltex high voltage generator.

Modifications or changes made to the distributor are not permitted.

Use only original Eltex spare parts and equipment.

### 2.2 Identification of risks and hazards

Possible risks and hazards resulting from the use of units are referred to in these operating instructions by the following symbols:



#### **Warning!**

This symbol appearing in the operating instructions refers to operations which, if carried out improperly, may result in serious personal injuries.



#### **Caution!**

This symbol appearing in the operating instructions refers to operations which, if carried out improperly, may result in damage to property.

## 2.3 Work and operational safety



### Warning!

Carefully observe the following notes and the complete [chapter 2 "Safety", page 9!](#)

- Always switch off the generator and disconnect the mains power supply before making any repairs and before cleaning and servicing the distributor, the generator and the bars (see [chapter 5 "Maintenance", page 15](#)).
- Before carrying out any work involving the units, the machine which has the units fitted must not be in operation (see [chapter 5 "Maintenance", page 15](#)).
- Any work involving the units must be carried out by qualified electricians (see [chapter 5 "Maintenance", page 15](#)).
- Connect / disconnect the high voltage cables only if the generator is switched off (see [chapter 3.3 "Connecting the high voltage cable", page 12](#)).
- In applications involving moving bars (e.g. film draw strips), the high voltage cable must be attached such that there is no cable movement near the connection zone of the generator (see [chapter 3.3 "Connecting the high voltage cable", page 12](#)).
- The high voltage cable must be pushed up to the stop into the cable inlet! The connecting area of the high voltage cable must be kept clean (see [chapter 3.3 "Connecting the high voltage cable", page 12](#)).
- Seal unused connecting sockets with sealing caps (see [chapter 3.3 "Connecting the high voltage cable", page 12](#), [chapter 5 "Maintenance", page 15](#)).
- Before starting up the unit, make sure that the distributor has been mounted correctly, that the high voltage cables have been installed properly and that the connections at the distributor are in good working (see [chapter 4 "Operation", page 14](#)).
- The generator may only be operated with max. 30 kV when using the extension cable and the PCV distributor and with max. 60 kV when using the PCV6 distributor (see [chapter 4 "Operation", page 14](#)).
- Make sure that the cable inlets and the connections are clean at all times (see [chapter 5 "Maintenance", page 15](#)).
- Check the electric leads and high voltage cables at regular intervals. Any damaged components must be repaired or replaced before the operation of the unit is continued.

## 2.4 Technical advance

The manufacturer reserves the right to make changes to the technical specifications without prior notice in order to adapt the units to state-of-the-art engineering. Eltex will provide the latest information on any changes or modifications in the operating instructions on request.

## 3. Installation and assembly

### 3.1 Assembly of the distributor

The PCV distributor is designed for wall-mounted installation and is attached via mounting brackets (see chap. 7, installation drawing). Make sure that the connections remain accessible at all times.

The plug socket of the extension cable can be mounted on a wall using the enclosed pipe clamps.

### 3.2 Selecting the charging bar

Eltex charging bars for DC operation can be connected to the extension cable and the distributors using charging plug Y.

### 3.3 Connecting the high voltage cable



#### **Warning!**

Electric shock hazard!

Work may be carried out only if:

- the supply voltage to the generator has been disconnected
- the machine is at a standstill because the bars pick up charges if the material web is running.

#### **Method:**

Connect the bars via the prefabricated high voltage cable. Push the high voltage cables up to the stop into the socket connection. Finally, secure the screwing. Unused high voltage outputs must be closed with the sealing cap.



#### **Warning!**

In applications involving moving bars (e.g. film draw strips), the high voltage cable must be attached such that there is no cable movement near the connection zone of the generator.

If no charging bar is connected to the respective plug connection of the generator, the connection must be closed with the sealing cap provided.

#### **Note:**

The screw connection must be fastened with a torque of 3 Nm.



#### **Caution!**

The high voltage cable must be pushed up to the stop into the cable inlet! The connecting area of the high voltage cable must be kept clean!

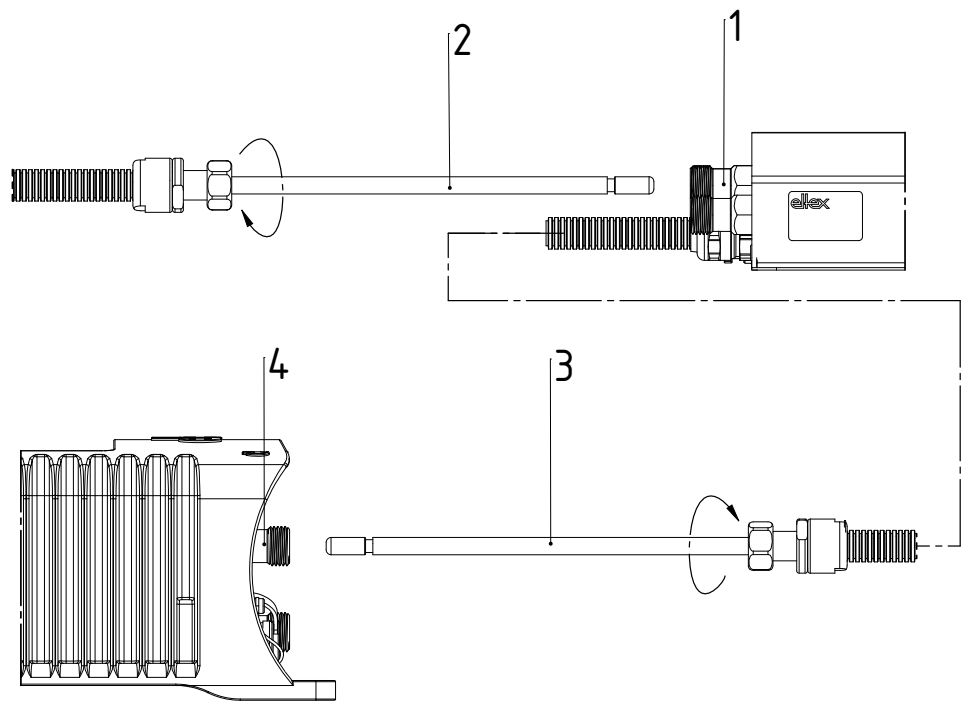

**Fig. 4:**  
*Connection of the  
 high voltage cable*

- 1 High voltage output PCV, shown without sealing cap
- 2 High voltage plug Charging bar
- 3 High voltage plug PCV
- 4 High voltage output POWER CHARGER generator, shown without sealing cap

Z-117457ay\_1

## 4. Operation



### 4.1 Startup

Before starting up the unit, make sure that the distributor has been mounted correctly, that the high voltage cables have been installed properly and that the connections at the distributor are in good working order.

The extension cable resp. the distributor is now operational.

The high voltage can now be switched on at the generator.



The generator may only be operated with max. 30 kV when using the extension cable and the PCV distributor and with max. 60 kV when using the PCV6 distributor.

## 5. Maintenance



### Warning!

Electric shock hazard!

- Switch the generator off and disconnect the supply voltage before carrying out any maintenance or repair work.
- The machine which has the units fitted must not be in operation.
- Any work involving the units must be carried out by qualified electricians.

### Distributor

- The extension cable and the distributor do not require any special maintenance. Make sure that the connections are placed correctly!
- Seal unused connecting sockets with sealing caps.
- The cable inlets must be kept clean.

## 6. Technical specifications PCV, PCV6 and extension cable KA

Supply voltage	PCV, KA/_Y: max. 30 kV DC PCV6: max. 60 kV DC
Operating ambient temperature	0...+70°C (+32...+158°F)
Storage temperature	-10...+80°C (+14...+176°F)
Ambient humidity	max. 80 % r.h., non-dewing
High voltage connections	1 resp. 2 resp. 4 pcs. plug-type
Housing	stainless steel with mounting drill-holes resp. mounting clamps
Dimensions	KA/_Y: 27 x 258 mm (Ø x L), see Fig. 8  PCV/2, PCV/Y: 210 x 120 x 56 mm (L x W x H), see Fig. 5, Fig. 6  PCV/4: 210 x 180 x 56 mm (L x W x H), see Fig. 5  PCV6/2: 210 x 120 x 56 mm (L x W x H), without cable connections, see Fig. 7  PCV6/4: 210 x 180 x 56 mm (L x W x H), without cable connections, see Fig. 7
Weight	KA/_Y: approx. 0.5 kg (without high voltage cable)  PCV_/2, PCV/Y: approx. 1.4 kg (without high voltage cable)  PCV_/4: approx. 2.5 kg (without high voltage cable)





## 7. Dimensions

### 7.1 Distributor PCV (max. 30 kV)

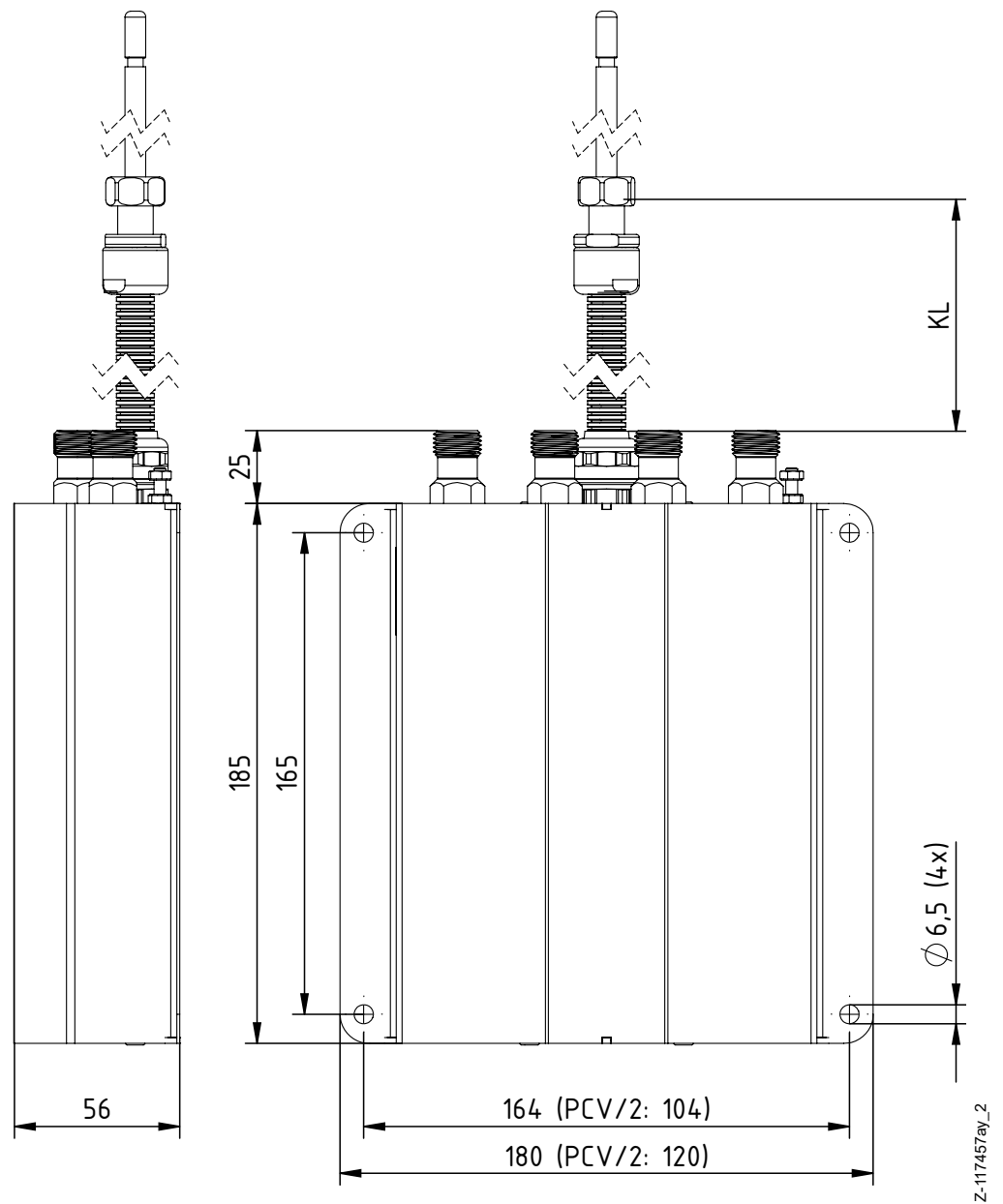

Fig. 5:  
Dimensions  
Distributor  
PCV/2, PCV/4

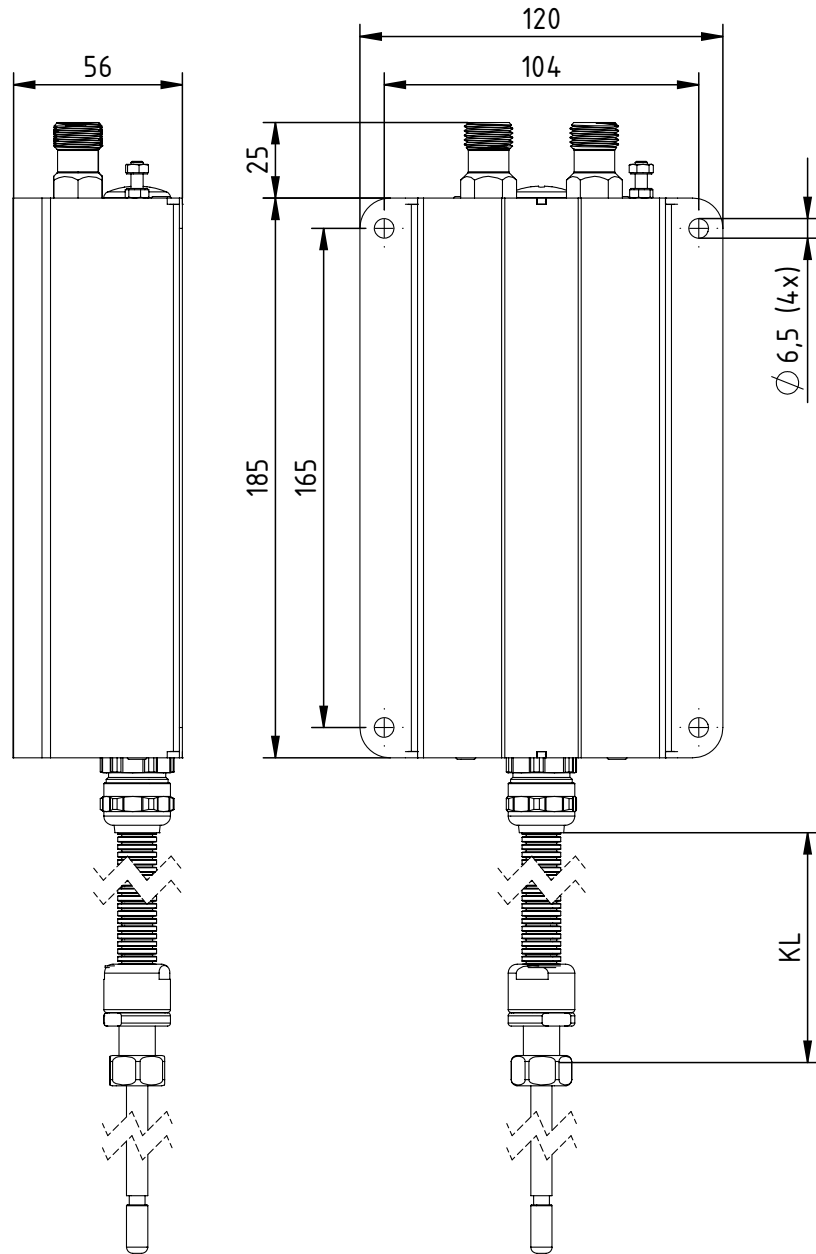

Fig. 6:  
Dimensions  
Distributor PCV/Y

Z-117457ay\_3

## 7.2 Distributor PCV6 (max. 60 kV)

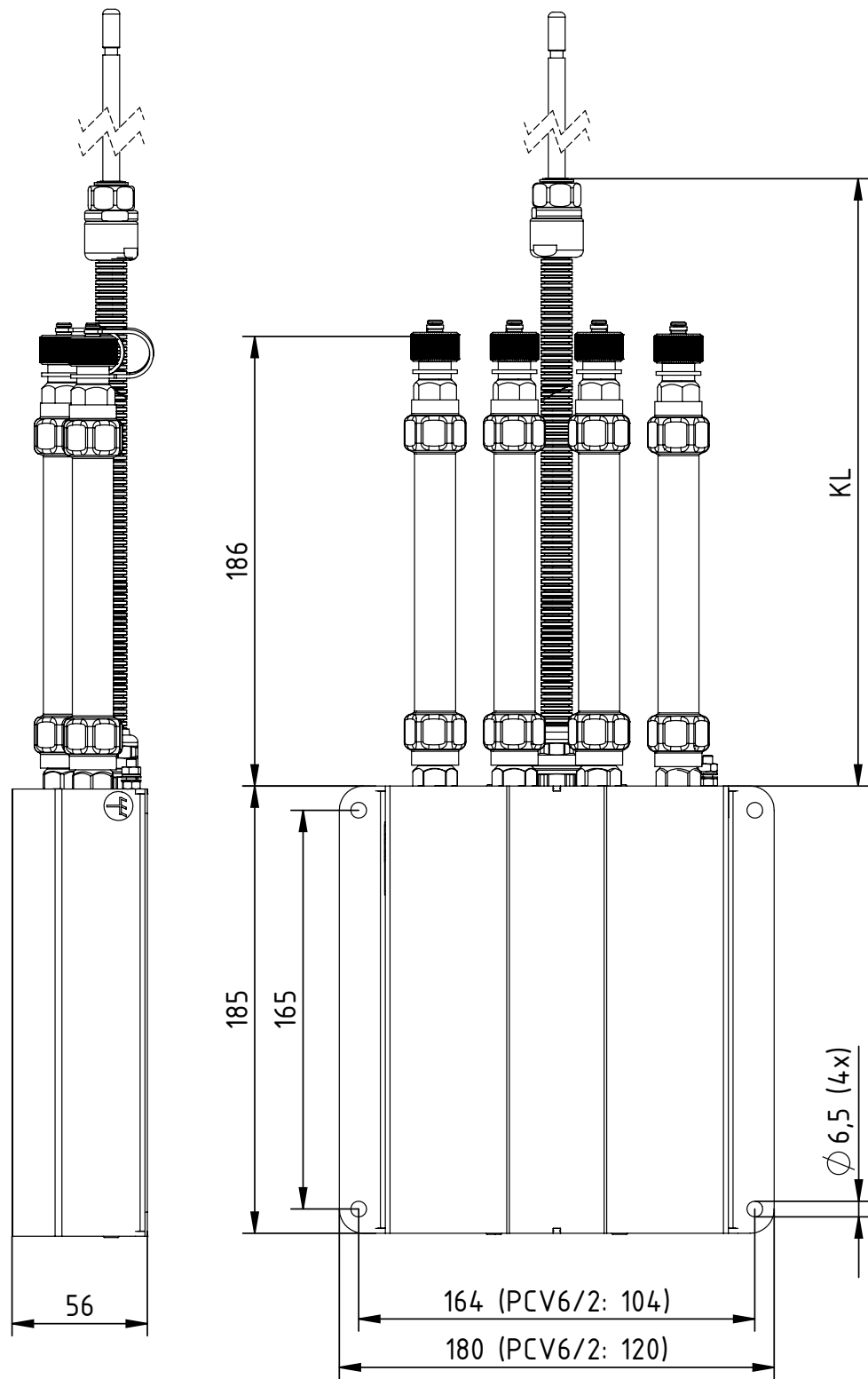

Fig. 7:  
Dimensions  
Distributor  
PCV6/2, PCV6/4

Z-118054ay\_2

### 7.3 Extension cable KA/YY\_ \_ \_ (max. 30 kV)

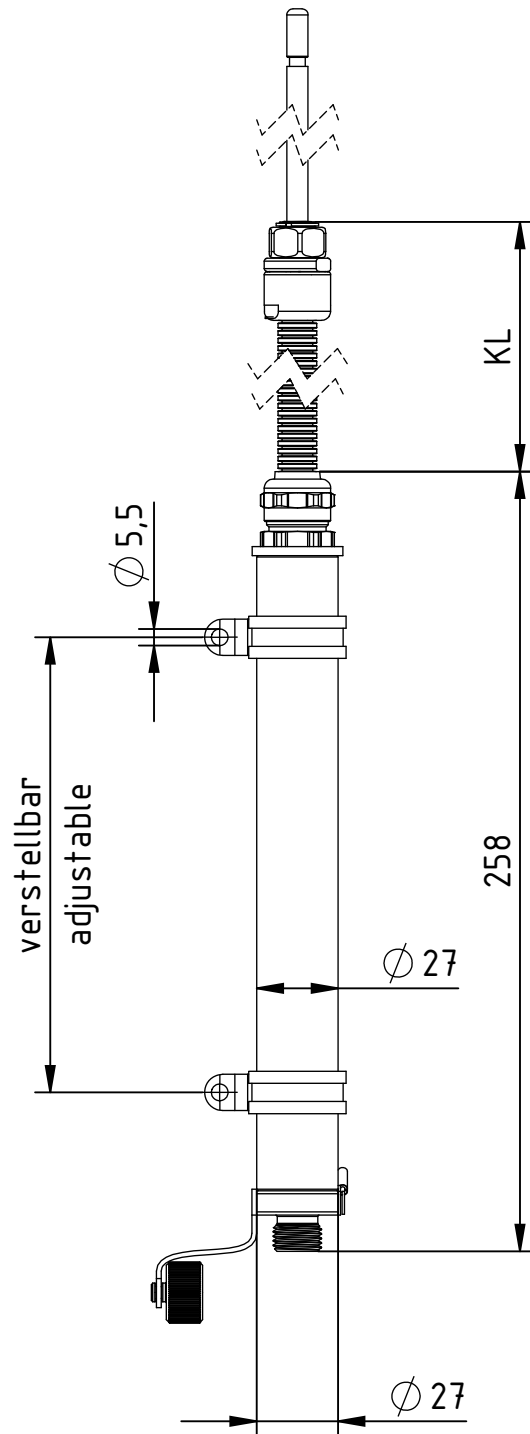

Fig. 8:  
Dimensions  
Extension cable  
KA/YY\_ \_ \_

Z-117693ay\_1y

## 8. Spare parts and accessories

Article	Article No.
Plug "Y" Set for prefabricating the high voltage cable with flexible tube for 30 kV charging bars for connection of the generator POWER CHARGER PC__ _ resp. modification set for charging plug Y	117985
Plug "R" Set for prefabricating the high voltage cable with flexible tube for 30 kV charging bars for connection of the generators KNH__ _	104165
Plug "X" Set for prefabricating the high voltage cable with flexible tube for 60 kV charging bars for connection of the generator POWER CHARGER PC__ _ resp. modification set for charging plug X	117986
Plug "U" Set for prefabricating the high voltage cable with flexible tube for 60 kV charging bars for connection of the generators KNH__ _	109501
Flexible tube for high voltage cable (specify length)	MCH02184
Sealing cap for high voltage output	116032
Operating instructions (specify language)	BA-xx-3042

Please specify the article number when ordering.

# EU-Declaration of Conformity

CE-3042-en-2411

Eltex-Elektrostatik-Gesellschaft mbH  
Blauenstraße 67 - 69  
D-79576 Weil am Rhein



declares in its sole responsibility that the product

## Distributor PCV, PCV6 (according to Eltex reference code

complies with the following directives and standards.

Relevant EU-Directive:

**2014/35/EU**

Low Voltage Directive

Harmonized standard applied:

EN 60204-1:2018

Safety of machinery – Electrical equipment of machines –  
General requirements

Relevant EU-Directives:

**2011/65/EU**

RoHS Directive

**(EU) 2015/863**

RoHS Delegated Directive

in the version effective at the time of delivery.

Eltex-Elektrostatik-Gesellschaft mbH keep the following documents for inspection:

- proper operating instructions
- plans
- other technical documentation

Weil am Rhein, 05.11.2024  
Place/Date

A blue ink signature of Lukas Hahne, written in a cursive style. Below the signature is a horizontal line.  
Lukas Hahne, Managing Director

# UKCA Declaration of Conformity

CA-3042-en-2208

Eltex-Elektrostatik-Gesellschaft mbH  
Blauenstraße 67 - 69  
D-79576 Weil am Rhein



declares in its sole responsibility that the product

**Distributor PCV, PCV6** (according to Eltex reference code

complies with the following directives and standards.

Applicable Regulation:

**S.I. 2016 No. 1101**

Electrical Equipment (Safety) Regulations

Used Designated Standard:

BS EN 60204-1:2018

Applicable Regulation:

**S.I. 2012 No. 3032**

RoHS Regulations

in the version effective at the time of delivery.

Eltex-Elektrostatik-Gesellschaft mbH keep the following documents for inspection:

- proper operating instructions
- plans
- other technical documentation

Weil am Rhein, 30.08.2022  
Place/Date



Lukas Hahne, Managing Director

# Eltex offices and agencies

The addresses of all  
Eltex agencies can be  
found on our website at  
[www.eltex.de](http://www.eltex.de)



z01007y



Eltex-Elektrostatik-Gesellschaft mbH  
Blauenstraße 67-69  
79576 Weil am Rhein | Germany  
Phone +49 (0) 7621 7905-422  
eMail [info@eltex.de](mailto:info@eltex.de)  
Internet [www.eltex.de](http://www.eltex.de)