

Operating Instructions

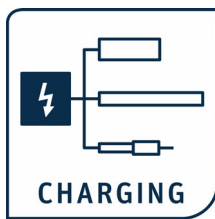

F01064y



High voltage generator POWER CHARGER PC

BA-en-3041-2408



Content

1	Outline of Appliance	7
1.1	Variants	9
1.2	High voltage setting range	11
2	Safety	13
2.1	Identification of risks and hazards	13
2.2	Contact protection	13
2.3	Technical advance	13
2.4	Proper Use	14
2.5	Work and operational safety	14
3	Installation	18
3.1	Assembly of the high voltage generator	18
3.2	Ground connection	19
3.3	Installation of the high voltage cables	20
3.4	Bars suitable for connection	21
3.4.1	Charging bars suitable for connection	21
3.4.2	Discharging bars suitable for connection	23
3.5	Connecting the charging bar to the high voltage generator	23
3.6	Connecting the discharging bar to the high voltage generator	24
3.7	Disconnecting the high voltage cable	25
3.8	Connecting the supply voltage	25
3.8.1	Connecting the supply voltage 24 V DC	25
3.8.2	Connecting the supply voltage 90 - 264 V AC	26
3.9	Fieldbus Interface	26
3.9.1	CANopen® (optional)	27
3.9.2	ModbusTCP (optional)	28
3.9.3	PROFINET (optional)	29
3.10	Analog Interface	30
3.10.1	I/O interface Charge	30
3.10.1.1	Release circuit Charge	32
3.10.2	I/O interface Discharge (optional)	33
3.10.2.1	Release circuit Discharge (optional)	34
3.11	Use of the Eltex signal cable CS and mains cable KN	35
4	Operation	38
4.1	Startup	38
4.2	Function monitoring	39
4.3	Realising the high voltage	46
4.4	Integrated control elements	47
4.4.1	Using the membrane keyboard	47
4.4.2	Using the display	58
4.4.2.1	Release	59
4.4.2.2	Configuration	59
4.4.2.2.1	ECC User	60

4.4.2.2.2	Access Management	61
4.4.2.2.3	Settings (Language, Standard access level, indication of the voltage and current values)	62
4.4.2.2.4	Highlight Values	63
4.4.2.2.5	Factory Settings	63
4.4.2.2.6	Login	63
4.4.2.3	Preset	64
4.4.2.4	Eltex DEBUG overview / Message overview	65
4.4.2.5	Parameters	66
4.4.2.6	General Parameters	67
5	Maintenance	68
5.1	High voltage generator	68
5.2	Charging bars / Discharging bars	68
6	Troubleshooting	69
6.1	Error messages	69
6.2	Warning messages	78
7	Technical Specifications POWER CHARGER PC_ _	81
8	Dimensions	84
8.1	High voltage generator PC	84
8.2	Distributor PCV PCV6 (optional)	85
8.2.1	Distributor PCV (max. 30 kV)	85
8.2.2	Distributor PCV6 (max. 60 kV)	87
8.3	Extension cable KA/YY_ _ _ (max. 30 kV)	88
9	Spare parts and accessories	89
10	Decommissioning / Battery removal	91
A	ANNEX	92
A.1	Assembly of the plugs	92
A.1.1	Plug M16 for 24 V DC supply voltage straight version, version with shield clamping ring	92
A.1.2	Plug for power cable for AC supply voltage	93
A.1.3	Plug M12, 8-pin for analog interface Charging	94
A.1.4	Plug M12, 5-pin for analog interface Discharging	94
A.2	Pollution monitoring	95
A.3	Detection of flashes	96
A.4	Overview of the actual values and parameters	97
A.4.1	Actual values: Charging	97
A.4.2	Actual values: Discharging	98
A.4.3	Actual values: General	98
A.4.4	Charging Parameters	99
A.4.5	Discharging Parameters	100
A.4.6	General Parameters	101
A.4.7	Interface Parameters	101
	Declaration of Conformity	102
	UKCA Conformity	103

Dear customer,

The POWER CHARGER PC high voltage generator is a universal high voltage supply unit for controlled charging and use of electrostatic effects.

The following bars may be connected:

Charge:

System variants PCSC, PCTL, PCRT und PCRM:

- R130A3 / R130A6 / R130A3L
- R120 voltage limitation, note Operating Instructions R120
- R23ATR / R23ATR11
with fixed high voltage cable
- EXR130A3: only for generators of the following types:
PC_/_/_______E, PC_/_/_______D
voltage limitation, see table page 10

System variantee PCMT:

- R170A3 voltage limitation, see table page 10

Discharge:

- Variant "A" (not for Performance Level applications)
R50
EXR5C
R60
R60L

This document contains the general, cross-system operating instructions for all generators of the POWER CHARGER family. For supplements, limitations and particularities specific to your system, please see the appropriate system manual.

All generators of the POWER CHARGER PC family offer the following features:

- Up to 50% higher charging power than comparable Eltex charging generators
- Parallel control of charging voltage, charging current and charging capacity
- Temperature-controlled power limitation
- Robust, compact design
- Easy installation
- Low weight
- Industry-grade high voltage plug connection
- Integrated function and error monitoring
- LED display for visualization of the operating status
- Touchscreen operation (optional)
- Easy setup via an I/O interface
- Integration of the generator into CANopen® networks (optional)
- Industrial Ethernet support (optional)

The language setting for the display variant can be found in [Chapter 4.4.2.2.3 "Settings \(Language, Standard access level, indication of the voltage and current values\)", page 62.](#)

Please read these instructions carefully before starting the unit. This will help you prevent personal injuries and damage to property.

Simply give us a call if you have any suggestions, proposals or ideas for improvements. We greatly appreciate the feedback from the users of our appliances

1. Outline of Appliance

Fig. 1:
High voltage
generator
POWER
CHARGER
with field bus

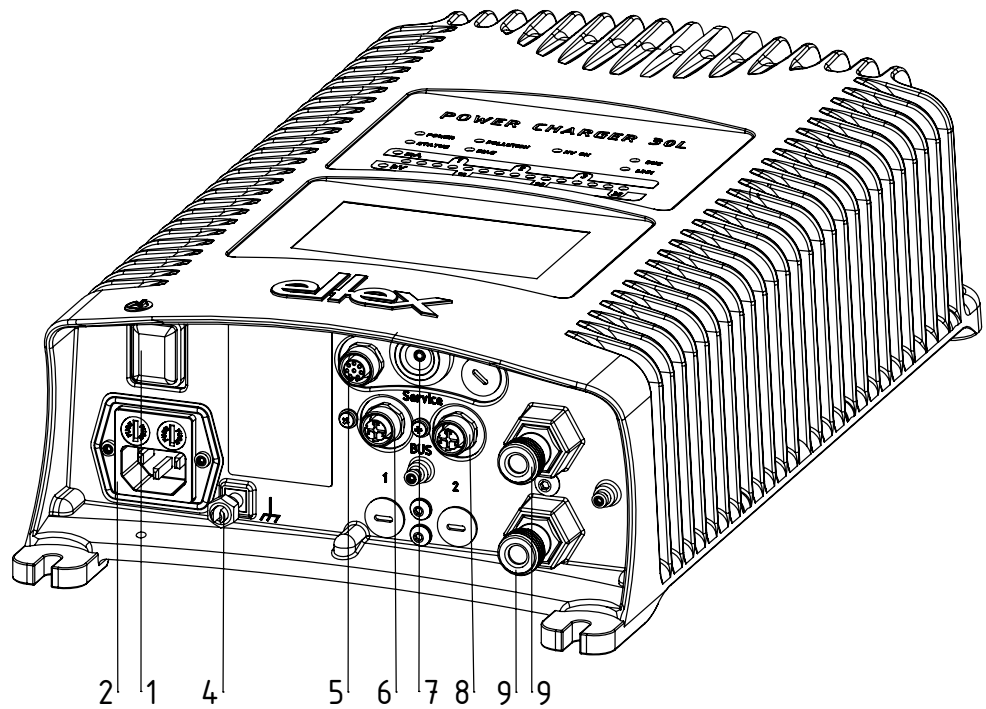

Z-116035by_1

Fig. 2:
High voltage
generator
POWER
CHARGER
with discharge

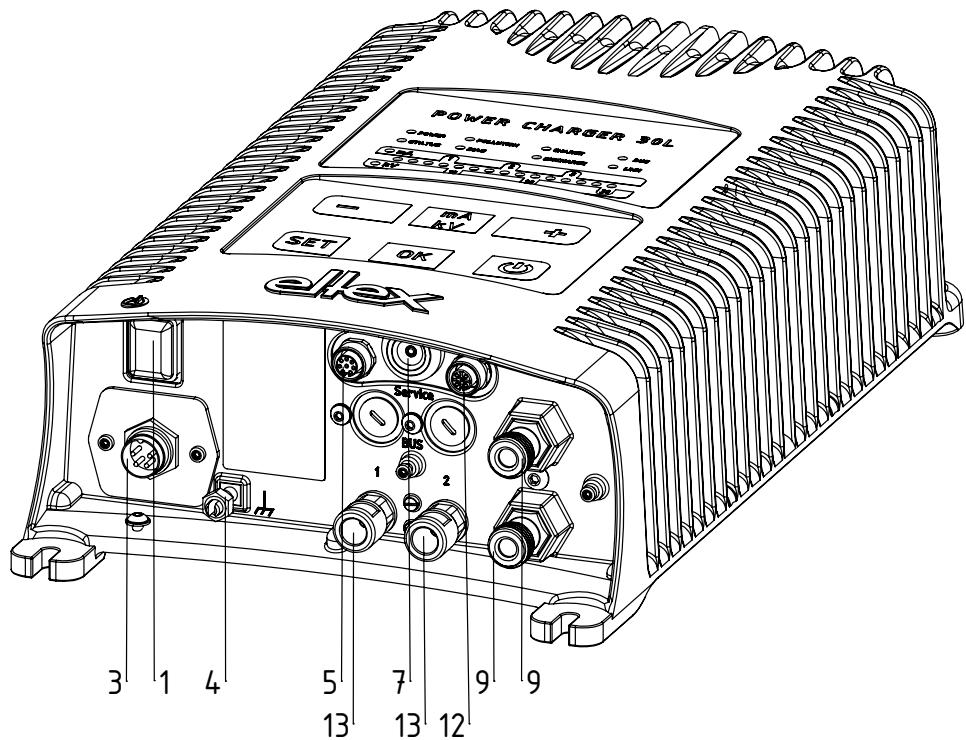

Z-116035by_2

Fig. 3:
High voltage
generator
POWER
CHARGER with
charging bars
suitable for
connection

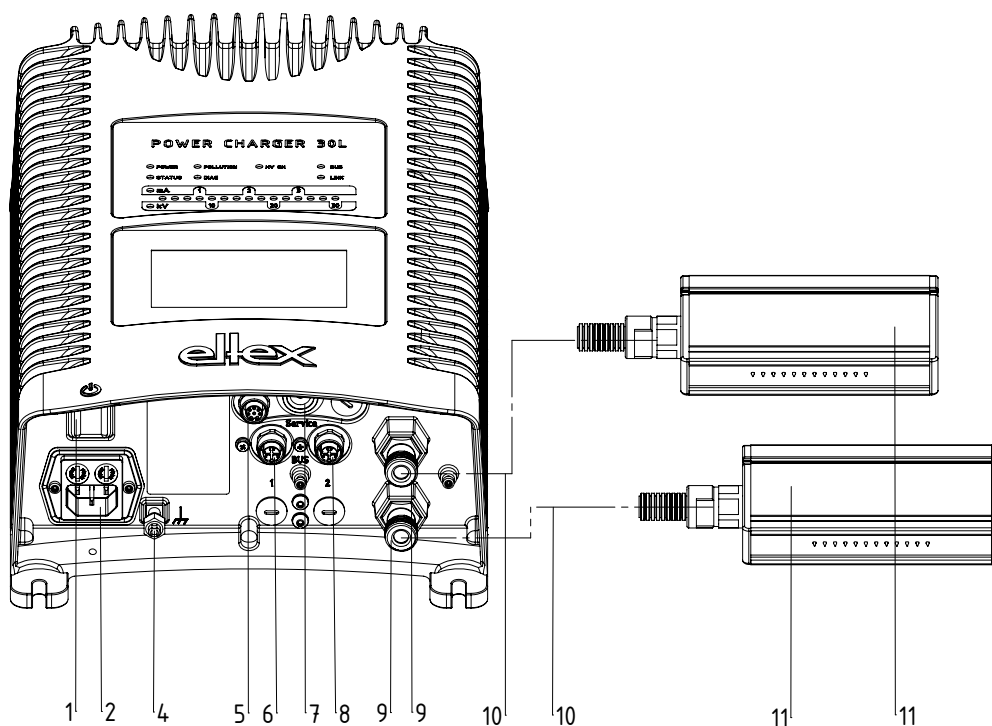

- 1 Operating switch ON/OFF
- 2 System input 90 - 264 V AC
- 3 System input 24 V DC
- 4 Ground terminal
- 5 I/O interface Charge
- 6 Interface 1 Field bus
- 7 Service interface
- 8 Interface 2 Field bus
- 9 High voltage output: Connection of the charging bar
- 9.1 High voltage output illustrated with a protective cap
- 10 High voltage cable
- 11 Charging bar
- 12 I/O interface Discharge
- 13 High voltage output Discharge

Z-116035by_3

	Article-No.	Version		Standard Version
1	Variable	Discharge	X A	No Discharge Active Discharge series R50 / EXR5C* *not in combination with P, D under variable 8
2	Variable	Polarity	N P	Negative Positive
3	Variable	Voltage	3 6	30 kV-Version 60 kV-Version
4	Variable	Supply / Output power	L S H	24 V DC, 75 W Mains voltage 90 / 264 V AC, 75 W Mains voltage 90 / 264 V AC, 150 W
5	Variable	Accessory Plug / Cable	O L C E U	No plug / cable included 24 V plug Plug for power cable, confectionable Power cable with plug EU (CEE 7/7) Power cable with plug NA (NEMA 5-15)
6	Variable	Display	X D	Without Display Display integrated
7	Variable	Interface	A C M P	I/O interface I/O interface + CANopen® I/O interface + ModbusTCP I/O interface + PROFINET
8	Variable	Certification	X XX P E EX D	UL Certification CE Self declaration Performance Level d and UL Certification Suitable for operation with Ex-bars deviating max. output voltage, see table page 11 and UL Certification Suitable for operation with Ex-bars deviating max. output voltage, see table page 11 Performance Level d and suitable for operation with Ex-bars deviating max. output voltage, see table page 11 and UL Certification
9	Variable	Version	000	Standard Version

1.2 High voltage setting range

Depending on the selected variant, you can set different maximum values for the output voltage, output current and output power.

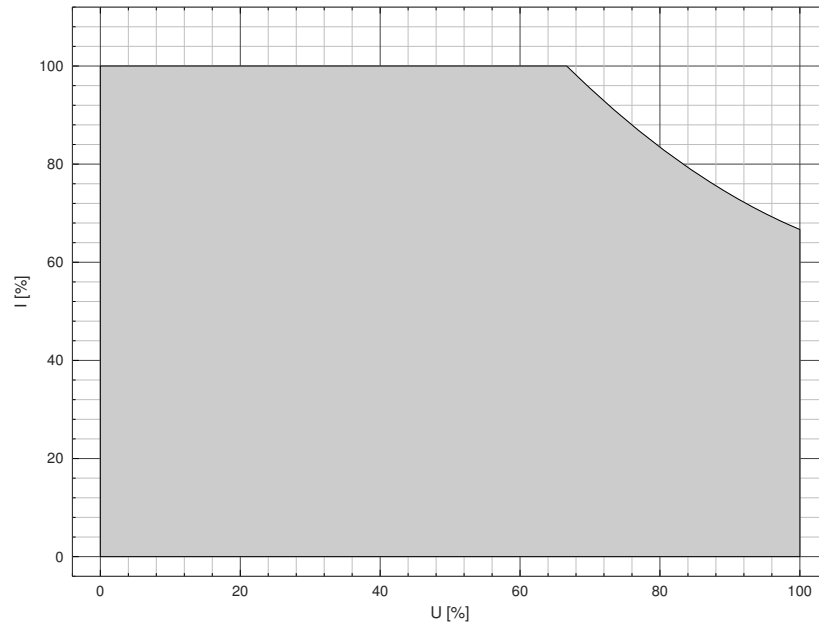

Fig. 4:
Diagram
Dependance
Current / Voltage

F00058y

Output voltage / - current for use in combination with charging bars EXR130A3 / R170A3

Variant	Umin	Umax	Imin	Imax
PC_ / N3L_ _E PC_ / N3L_ _D PC_ / N3S_ _E PC_ / N3S_ _D	1.5 kV	27 kV	50 μ A	3.75 mA
PC_ / N3H_ _E PC_ / N3H_ _D	1.5 kV	27 kV	50 μ A	7.5 mA
PC_ / P3L_ _E PC_ / P3L_ _D PC_ / P3S_ _E PC_ / P3S_ _D	1.5 kV	18 kV	50 μ A	3.75 mA
PC_ / P3H_ _E PC_ / P3H_ _D	1.5 kV	18 kV	50 μ A	7.5 mA
PCMT/ _3L PCMT/ _3S	1.5 kV	18 kV	50 μ A	3.75 mA
PCMT/ _3H	1.5 kV	18 kV	50 μ A	7.5 mA

Dependance current / voltage

Supply / output power	Variable output voltage 30 kV	Variable output voltage 60 kV
L = 24 V DC, 75 W S = 90/264 V AC, 75 W	3.75 mA at 20 kV 2.5 mA at 30 kV	1.875 mA at 40 kV 1.25 mA at 60 kV
H = 90/264 V AC, 150 W	7.5 mA at 20 kV 5 mA at 30 kV	3.75 mA at 40 kV 2.5 mA at 60 kV

Initial values min / max

Supply / output power	Variable output voltage 30 kV	Variable output voltage 60 kV
L = 24 V DC, 75 W S = 90/264 V AC, 75 W	U _{min} = 1.5 kV I _{min} = 50 µA U _{max} = 30 kV I _{max} = 3.75 mA	U _{min} = 6 kV I _{min} = 50 µA U _{max} = 60 kV I _{max} = 1.875 mA
H = 90/264 V AC, 150 W	U _{min} = 1.5 kV I _{min} = 50 µA U _{max} = 30 kV I _{max} = 7.5 mA	U _{min} = 6 kV I _{min} = 50 µA U _{max} = 60 kV I _{max} = 3.75 mA

2. Safety

The units have been designed, built and tested using state-of-the-art engineering, and have left the factory in a technically and operationally safe condition. If used improperly, the units may nevertheless be hazardous to personnel and may cause injury or damage. Read the operating instructions carefully and observe the safety instructions.

For warranty conditions, please refer to the General Terms and Conditions (GTC), see www.eltex.de.

2.1 Identification of risks and hazards

Possible risks and hazards resulting from the use of the units are referred to in these operating instructions by the following symbols:



Warning!

This symbol appearing in the operating instructions refers to operations which, if carried out improperly, may result in serious personal injuries.



Caution!

This symbol appearing in the operating instructions refers to operations which, if carried out improperly, may result in damage to property.



Ex Warning!

For units with EX approval only.

This symbol denotes the special conditions which must be observed when operating the system in explosion hazard areas as specified in the EX approvals.

2.2 Contact protection

The site of installation and/or use of the units is outside the control of Eltex, contact protection against inadvertent contact of the bars and of live components by personnel as specified by the employer's liability insurance association may have to be provided (e.g. DGUV V3 in Germany). Contact protection devices made of conductive material must be grounded.

2.3 Technical advance

The manufacturer reserves the right to make changes to the technical specifications without prior notice in order to adapt the units to state-of-the-art engineering. Eltex will provide the latest information on any changes or modifications in the operating instructions on request.

2.4 Proper Use

The POWER CHARGER high voltage generator has been approved as operating voltage generator for the appropriate Eltex charging bars. It must be operated only with the appropriate Eltex bars (see chapter Installation and Assembly for bar models).

If the unit is used in any other high voltage application, the manufacturer's warranty covers the safe use in terms of technical safety.

The manufacturers will not assume any liability and warranty if the units are used improperly or used outside the intended purpose.

Modifications or changes made to the devices are not permitted.

Use only original Eltex spare parts and equipment.

2.5 Work and operational safety



Warning!

Carefully observe the following notes and the complete [Chapter 2 "Safety", page 13!](#)

Always observe the rules and regulations applying in your country with reference to electrical appliances.

- Before installation, carrying out repairs, cleaning or maintenance work and before resetting the unit after malfunctions, switch off the high voltage generator and disconnect the mains power supply on all units and associated components (see [Chapter 3 "Installation", page 18](#), [Chapter 5 "Maintenance", page 68](#), [Chapter 6 "Troubleshooting", page 69](#)).
- If electrically conductive substrates or substrates coated with conductive material (e.g. metal foil or metal composites) are used, the discharging voltage of the generator must be switched.
- Before carrying out any work involving the units, the machine which has the units fitted must not be in operation (see [Chapter 3 "Installation", page 18](#), [Chapter 5 "Maintenance", page 68](#), [Chapter 6 "Troubleshooting", page 69](#)).
- Any work involving the units must be carried out by qualified electricians (see [Chapter 3 "Installation", page 18](#), [Chapter 5 "Maintenance", page 68](#), [Chapter 6 "Troubleshooting", page 69](#), [Chapter 10 "Decommissioning / Battery removal", page 91](#)).
- The unit may only be used by qualified personnel trained for explosion hazard areas.
- A permanent grounding connection must be made and checked via the ground terminal before the startup of the generator. The ground cable should have a minimum cross section of 1.5 mm² and should be routed with the shortest possible distance to the machine frame. If the length of the cable is > 0.5 m, the cross section must be at least 2.5 mm². The

ground connection must be permanently ensured for the entire operating time of the generator (see [Chapter 3.2 "Ground connection", page 19](#)).

- When routing the high voltage cables, observe [Chapter 3.3 "Installation of the high voltage cables", page 20](#).
- The high voltage cable must be pushed up to the stop (150 mm) into the cable inlet! The connecting area of the high voltage cable must be kept clean (see [Chapter 3.5 "Connecting the charging bar to the high voltage generator", page 23](#)).
- If no charging/discharging bar is connected to the respective plug connection of the generator, the connection must be closed with the blind plug provided (see [Chapter 3.5 "Connecting the charging bar to the high voltage generator", page 23](#), [Chapter 3.6 "Connecting the discharging bar to the high voltage generator", page 24](#)).
- In applications involving moving bars (e.g. film draw strips), the high voltage cable must be attached such that there is no cable movement near the connection zone of the power supply unit (see [Chapter 3.5 "Connecting the charging bar to the high voltage generator", page 23](#), [Chapter 3.6 "Connecting the discharging bar to the high voltage generator", page 24](#)).
- Due to the power consumption of the high voltage generator, the cable cross-sections should be as large and the cables as short as possible in order to reduce cable loss (see [Chapter 3.8.1 "Connecting the supply voltage 24 V DC", page 25](#)).
- The voltage at the individual contacts must not exceed 60 V DC (see [Chapter 3.8.1 "Connecting the supply voltage 24 V DC", page 25](#), [Chapter 3.9 "Field bus Interface", page 26](#)).
- To prevent an interruption of the power supply due to vibrations or other mechanical influences, Eltex recommends using latched sockets to connect the power supply cable; see spare part no. 116329 (see [Chapter 3.8.2 "Connecting the supply voltage 90 - 264 V AC", page 26](#)).
- For the variant with CANopen®, a cable suitable for CAN bus networks with a surge resistance of 120 ohms must be used for both bus leads; this is the only way to ensure the proper functioning of the CAN network (see [Chapter 3.9.1 "CANopen® \(optional\)", page 27](#)).
- Generally, for the interface cables shielded cable should be used; the shields must be placed on both sides (see [Chapter 3.10.1 "I/O interface Charge", page 30](#), [Chapter 3.10.2 "I/O interface Discharge \(optional\)", page 33](#)).
- When using the optional Eltex signal cable CS or the mains cable KN, the colour markings and the bending radii should be observed when connecting the individual leads (see [Chapter 3.11 "Use of the Eltex signal cable CS and mains cable KN", page 35](#)).

- Check the high voltage generator, all connected units, the electrical wiring and the high voltage cables at regular intervals for any damage. Any damaged components must be repaired or replaced before continuing to operate the unit, or the appropriate units must be disabled.
- Make sure that the bars are clean at all times. Dirt on the bars may cause malfunctions and premature wear of the devices.
- Please note that for variants with active discharging and corresponding parameterization of the discharge mode as “active”, the hardware release for discharging must always precede the release for charging (see [Chapter 4.3 "Releasing the high voltage", page 46](#)).
- When cleaning the bars do not soak the bars in solvent and do not damage the emission tips; allow the solvent to evaporate completely before restarting the unit (see [Chapter 5 "Maintenance", page 68](#)).
- The IP54 protection class applies only if the lid of the enclosure is closed and the cable entries are covered.
- Before opening the generator, switch it off and disconnect all plug connectors and cables (see [Chapter 10 "Decommissioning / Battery removal", page 91](#)).
- **Battery replacement is not permitted.** There is a risk of explosion if the wrong type of battery is used (see [Chapter 10 "Decommissioning / Battery removal", page 91](#)).
- **Static on personnel**
 Static charges on personnel are unlikely if the bars are installed properly. Personnel must wear conductive footwear.
 Please note all national regulations regarding electrostatic charge (e.g. TRGS 727 in Germany).



Information on performance level applications:

- The 24 V DC power supply to be used must be tested according to the EN 60950-1 or EN 62368-1 standard / must meet the applicable PELV (protective extra low voltage) or SELV (safety extra low voltage) requirements (see [Chapter 3.8.1 "Connecting the supply voltage 24 V DC", page 25](#), [Chapter 7 "Technical Specifications POWER CHARGER PC ___", page 81](#)).
- A redundant release signal is required if the generator must comply with the safety requirements of DIN EN 13849. To this end, the two signals "Release +" and "Release -" must be transmitted via separate switching paths; hardwiring of the two release signals +/- is prohibited (see [Chapter 3.10.1 "I/O interface Charge", page 30](#), [Chapter 3.10.2 "I/O interface Discharge \(optional\)", page 33](#)).
- Release I/O interface
Be sure to connect the signals properly to avoid damaging the generator. Always use shielded cables as interface cables; the shield must be contacted at both ends (see [Chapter 3.10.1 "I/O interface Charge", page 30](#), [Chapter 3.10.2 "I/O interface Discharge \(optional\)", page 33](#)).
- The release signals for charging / discharging must be switched off at least once a year for 400 ms or longer so that errors in the enabling logic may be detected.
- The charging / discharging bars must be cleaned at least once a week to ensure that they function properly (see [Chapter 5.2 "Charging bars / Discharging bars", page 68](#)).
- The voltage at the input plugs of the 24 V DC supply voltage, the I/O interfaces for charging and discharging and the field bus interfaces must not exceed 60 V DC (see [Chapter 3.8.1 "Connecting the supply voltage 24 V DC", page 25](#), [Chapter 7 "Technical Specifications POWER CHARGER PC ___", page 81](#)).

3. Installation

3.1 Assembly of the high voltage generator

The unit is designed for wall mounting. The POWER CHARGER will be fastened to the lugs of the PC housing. When mounting the unit make sure that the operating elements and the connector terminals remain accessible and that control of the unit is not impaired.

The site of installation must be dry and free of dust, if possible. Air circulation must not be obstructed.

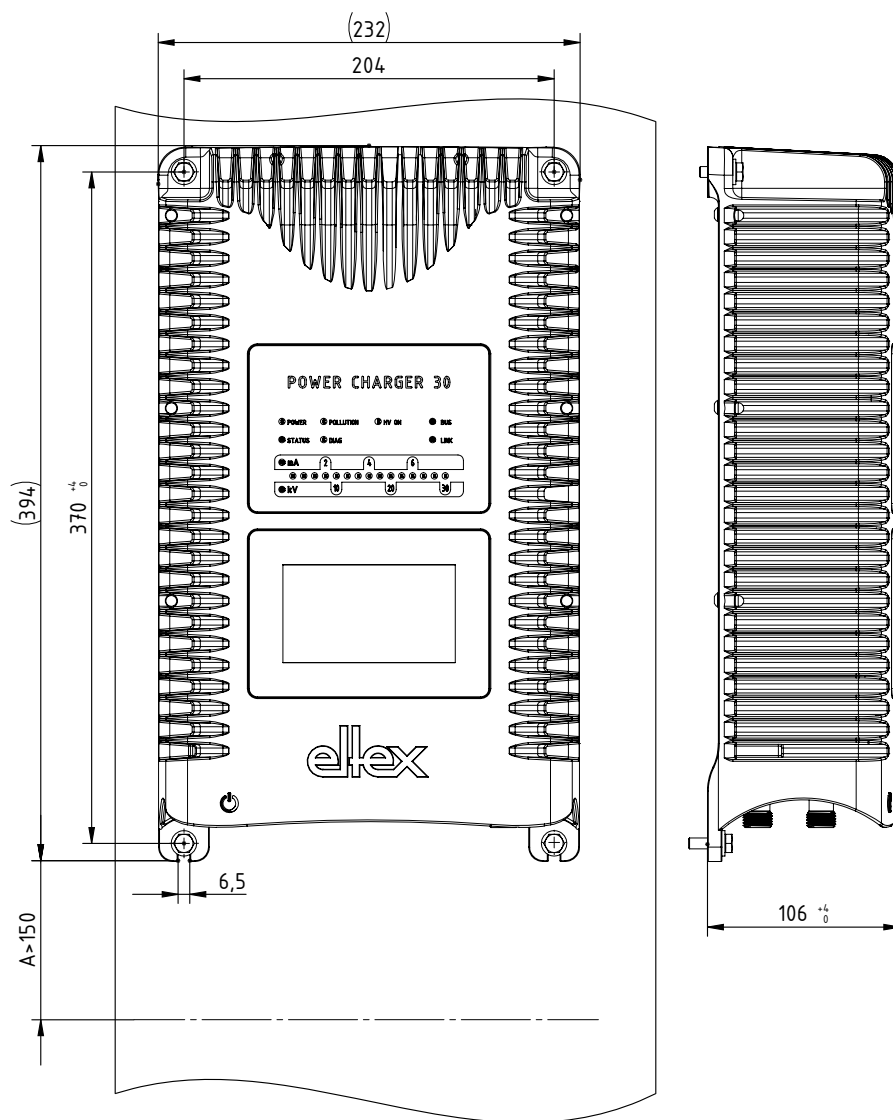

Fig. 5:
Installation of the
high voltage
generator,
vertical

Z-116036dy_2

Mounting position

Fig. 5 "Installation of the high voltage generator, vertical" and Fig. 6 "Installation of the high voltage generator, horizontal" show the two permitted mounting positions. Please note that the specified ambient temperature must not be exceeded at any time on any side of the housing.

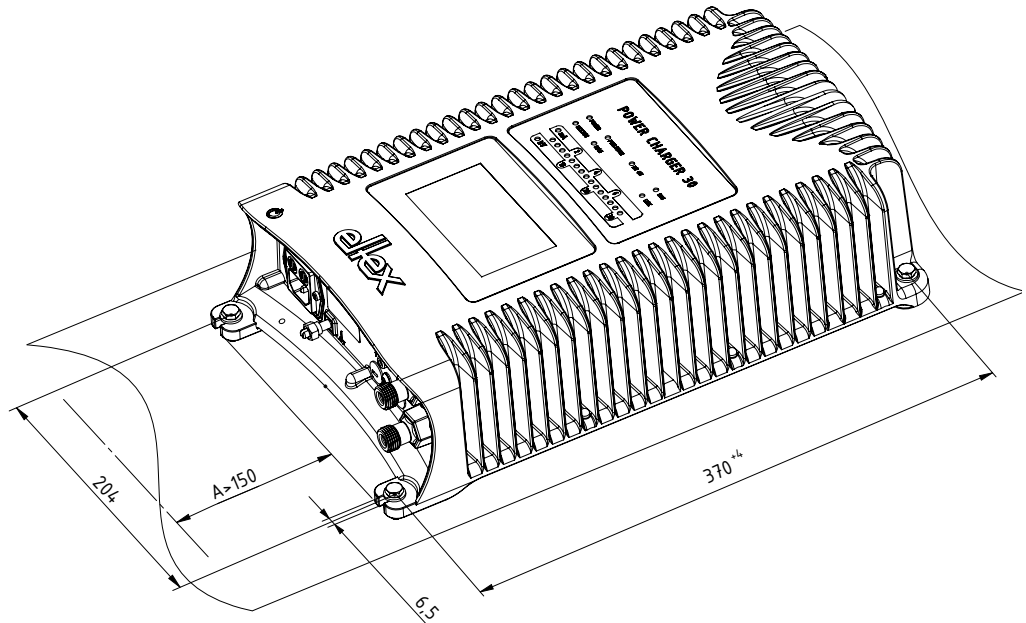

Fig. 6:
Installation of the
high voltage
generator,
horizontal

Z-116036dy_1

3.2 Ground connection



Attention!

A functioning ground connection must be ensured during the entire service life of the generator. The ground cable should have a minimum cross section of 1.5 mm^2 and should be routed with the shortest possible distance to the machine frame. A cross section of 2.5 mm^2 is required for cable lengths exceeding 0.5 meters. Eltex recommends using the ground cable supplied with the generator.

Ground terminal

Insert the ground cable into the side slot of the open terminal until it projects from the opposite side. Then tighten the integrated safety screw of the terminal up to the stop (5 Nm).

3.3 Installation of the high voltage cables

- A minimum bending radius of 10 times the external diameter must be maintained when routing the high voltage cable.
- The high voltage cables must not be attached with metal clips.
- Do not route the cable over sharp edges (bending radius <5 mm).
- Keep a minimum spacing of 50 mm between low voltage and high voltage cables; if this cannot be done, shield the low voltage cable.
- If the high voltage cables are led through bores in conductive, grounded materials, the minimum bore diameter D is calculated as follows from the wall thickness of the material:
Bore hole diameter D (mm) = $60 \text{ mm}^2 / \text{wall thickness (mm)}$
E.g. wall thickness 2 mm: $D = 60 \text{ mm}^2 / 2 \text{ mm} = 30 \text{ mm}$
Allow the biggest possible radius for the edges of the bore hole. Use an insulating grommet to centre the cable.
- If ungrounded and conductive objects are placed near ($\leq 2\text{m}$) the high voltage cable, influenced charges and sparking must be expected. Proper ground connection is therefore important.
- In applications using movable bars (e.g. film draw strips), route the high voltage cables such that there is no cable movement near the connection point to the generator.

3.4 Bars suitable for connection

3.4.1 Charging bars suitable for connection

The following charging bars may be connected to the high voltage generator POWER CHARGER PC__:

System variants PCSC, PCTL, PCRT und PCRM:

- R130A3 / R130A6 / R130A3L
- R120 voltage limitation, note Operating Instructions R120
- R23ATR / R23ATR11
with fixed high voltage cable
- EXR130A3: only for generators of the following types:
PC__ / _____ E, PC__ / _____ D
voltage limitation, see table page 10

System variant PCMT:

- R170A3 voltage limitation, see table page 10

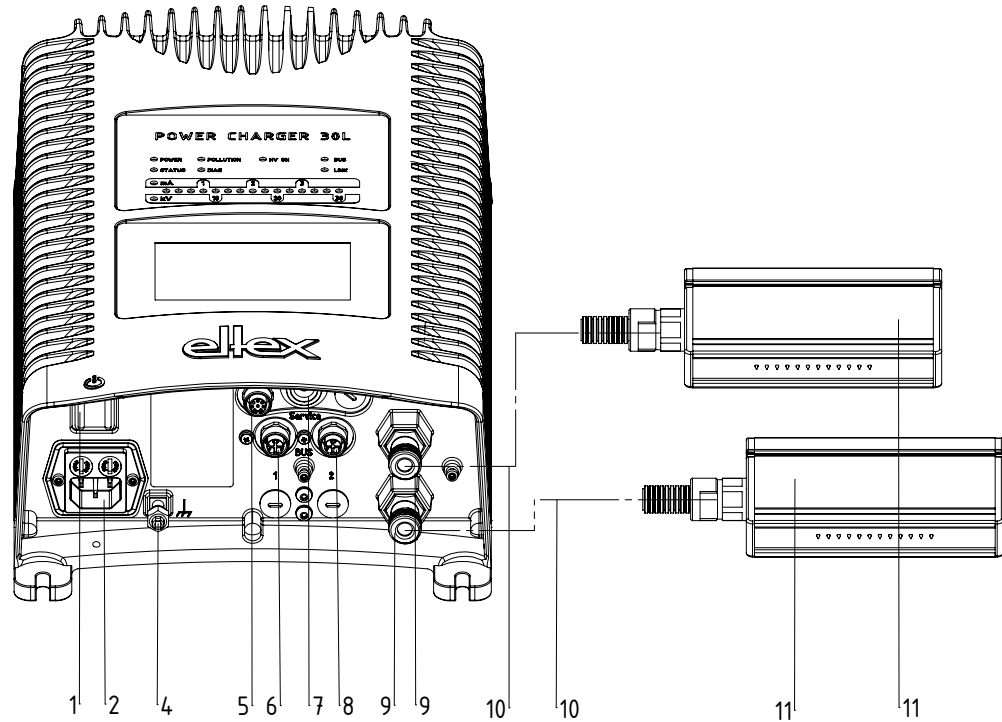
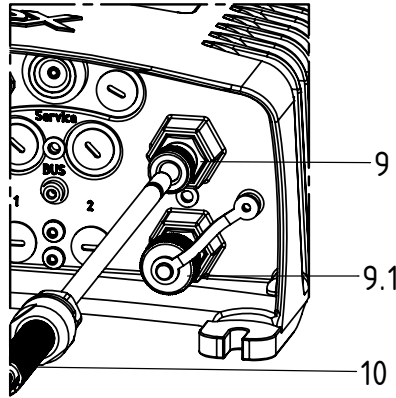

Fig. 7:
Installing the
generator and the
charging bars

- | | |
|------------------------------|--|
| 1 Operating switch ON/OFF | 7 Service interface |
| 2 System input 90 - 264 V AC | 8 Interface 2: Field bus |
| 3 System input 24 V DC | 9 High voltage output:
Connection of the charging bar |
| 4 Ground terminal | 10 High voltage cable |
| 5 I/O interface | 11 Charging bar |
| 6 Interface 1: Field bus | |

Z-116035by_3

Fig. 8:
Connection of the
high voltage cable



- 9 High voltage output:
Connection of the charging bar
- 9.1 High voltage output:
Connection shown with cover cap
- 10 High voltage cable

Example:
Current per meter of active bar length: 1 mA
Sum of active bar lengths: 3 m
=> maximum total current: 3 mA

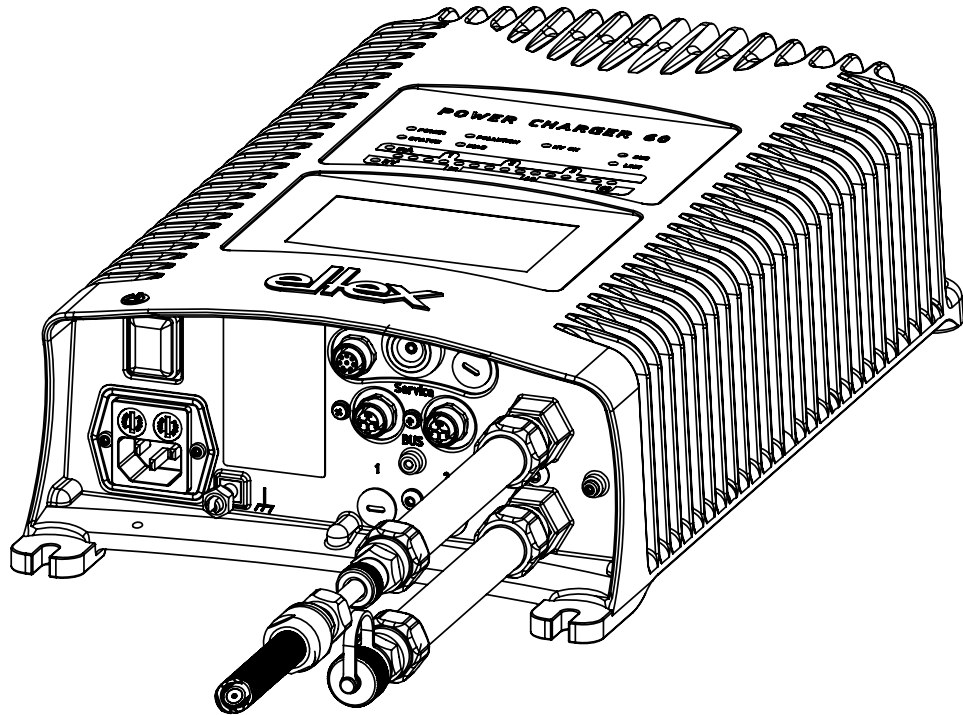
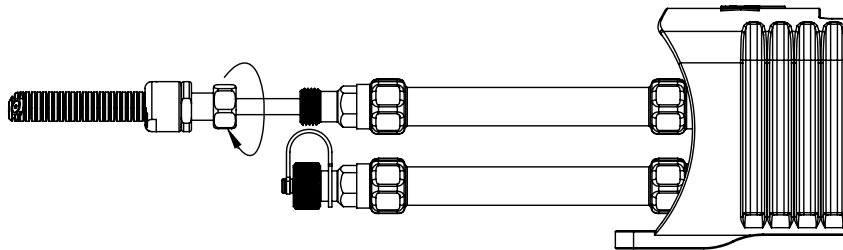

Fig. 9:

Fig. 10:
Connection of the
high voltage cable
at 60 kV



Z-116035c_5

Z-116035dy_6

Z-116035dy_7

3.4.2 Discharging bars suitable for connection

The following charging bars may be connected to the high voltage generator POWER CHARGER PC__:

- Variant "A" (not for Performance Level applications)
 - R50
 - EXR5C
 - R60
 - R60L

3.5 Connecting the charging bar to the high voltage generator



Warning!

Electric shock hazard!

Work may be carried out only if:

- the supply voltage to the generator has been disconnected
- the machine is at a standstill because the bars pick up charges if the material web is running.

Method:

Connect the bars via the prefabricated high voltage cable. Push the high voltage cables up to the stop into the socket connection. Finally, secure the screwing. Unused high voltage outputs must be closed with the sealing cap.

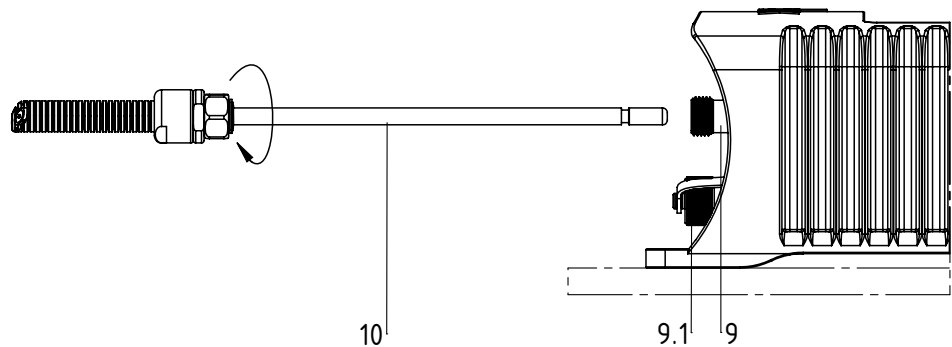

Fig. 11:
Connection of the
high voltage cable

9 / 9.1 High voltage outputs 10 High voltage cable
9.1 High voltage output shown with sealing cap



Warning!

In applications involving moving bars (e.g. film draw strips), the high voltage cable must be attached such that there is no cable movement near the connection zone of the power supply unit.

If no charging / discharging bar is connected to the respective plug connection of the generator, the connection must be closed with the blind plug provided.

Note:

The screw connection must be fastened with a torque of 3 Nm.



Caution!

The high voltage cable must be pushed up to the stop (150 mm) into the cable inlet! The connecting area of the high voltage cable must be kept clean!

3.6 Connecting the discharging bar to the high voltage generator



Warning!

Electric shock hazard!

Work may be carried out only if:

- the supply voltage to the generator has been disconnected
- the machine is at a standstill because the bars pick up charges if the material web is running.

Connect the discharge bars to the power supply using the prefabricated high voltage cable. Push the high voltage cables into the sockets up to the stop. Then secure the adapter in the socket with the clip provided (see Fig. 12).

Cables without adapter carry a coloured marking on the flexible tubing. This marking must lie flush with the outside edge of the coupling. Cables without flexible tube and cables with plug-type adapters are plugged in flush and secured with the clip.

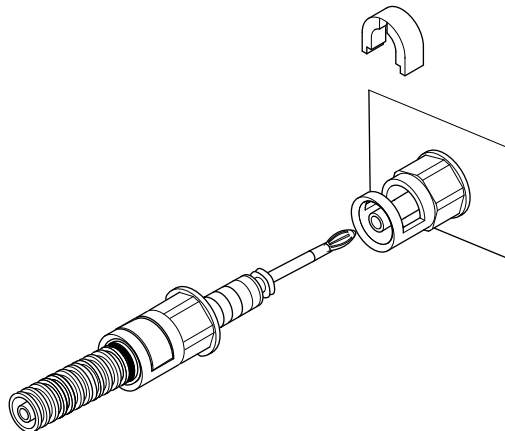

Fig. 12:
Connecting the
high voltage cable



Warning!

In applications involving moving bars (e.g. film draw strips), the high voltage cable must be attached such that there is no cable movement near the connection zone of the power supply unit.

If no charging / discharging bar is connected to the respective plug connection of the generator, the connection must be closed with the blind plug provided.

3.7 Disconnecting the high voltage cable



Warning!

Electric shock hazard!

Work may be carried out only if:

- the supply voltage to the generator has been disconnected,
- the machine is at a standstill because the bars pick up charges if the material web is running.

3.8 Connecting the supply voltage

To make sure that no high voltage is applied at the bars when the machine is not running, the supply voltage to the generator should be enabled via a machine contact which disables the high voltage when the machine is at rest.



Warning!

Electric shock hazard!

Work may be carried out only if:

- the supply voltage to the generator has been disconnected
- the machine is at a standstill because the bars pick up charges if the material web is running.

3.8.1 Connecting the supply voltage 24 V DC

The supply voltage of the high-voltage generator is connected to the 24 V DC supply network via the 4-pin circular connector.

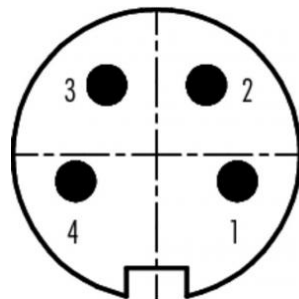

- | | |
|---|----------------|
| 1 | +24 V DC |
| 2 | +24 V DC |
| 3 | 0 V and ground |
| 4 | 0 V and ground |

wire color

- | |
|--------|
| white |
| brown |
| green |
| yellow |

Fig. 13:
Connector pin assignment
24 V DC plug
supply voltage

F00061Y



Caution!

The 24 V DC power supply to be used must be tested according to the EN 60950-1 or EN 62368-1 standard / must meet the applicable PELV (protective extra low voltage) or SELV (safety extra low voltage) requirements.

Due to the power consumption of the high voltage generator, the cable cross-sections should be as large and the cables as short as possible in order to reduce cable loss.

The voltage at the individual contacts must not exceed 60 V DC.

3.8.2 Connecting the supply voltage 90 - 264 V AC

The 90–264 V AC power supply is connected via the standard C13 device plug.

Fig. 14:
Connector pin
assignment
90 - 264 V AC
plug

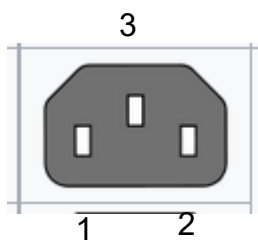

wire color

- | | | |
|---|----|----------------|
| 1 | L | brown or black |
| 2 | N | blue or black |
| 3 | PE | yellow/green |



Caution!

In case of customer's provision:

To prevent an interruption of the power supply due to vibrations or other mechanical influences, Eltex recommends using a plug for power cable, form C13 with integrated locking, see [Chapter 9 "Spare parts and accessories"](#), page 89.

3.9 Field bus Interface



Warning!

Electric shock hazard!

Work may be carried out only if:

- the supply voltage to the generator has been disconnected
- the machine is at a standstill because the bars pick up charges if the material web is running.



Caution!

The voltage at the individual contacts must not exceed 60 V DC.

3.9.1 CANopen® (optional)

The generators POWER CHARGER PC__ support the standardized CANopen® protocol according to CiA 301. The generator logs onto the network as a slave with the device profile 401 for input/output devices. The following CANopen® services are supported:

- Emergency Protokoll (EMCY) for the transmission of error and warning events
- Heartbeat Producer for node monitoring
- Static mapping for PDO transfer
All important data are available in PDOs.
- Prompt SDO transfer
Segmented transfers and block transfers are not supported.
- CANopen® objects for storing und restoring parameter data
- LSS services for setting the node address and baud rate (see chapter 4.4).

The complete description of the CANopen® protocol for the generator POWER CHARGER PC__ and the corresponding EDS file "PC.eds" are available in separate files. The files are available for download on the product page Charging/High voltage generators/POWER CHARGER at www.eltex.de.

The bus network has to be terminated at both sides.

Connector pin assignment CANopen®

Plug connector M12x1 A-coded

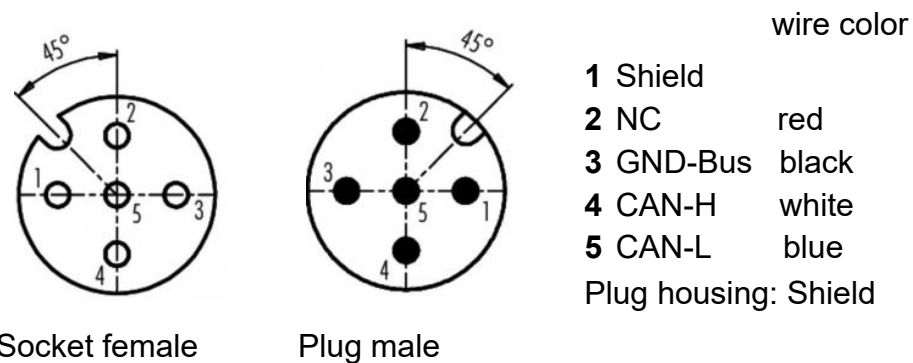

Fig. 15:
Connector pin
assignment
CAN-Bus female/
male



Caution!

For the variant with CANopen®, a cable suitable for CAN bus networks with a surge resistance of 120 ohms must be used for both bus leads; this is the only way to ensure the proper functioning of the CAN network.

The maximum cable lengths specified in CiA 303-1 as a factor of the transmission speed must be observed for the whole network and for the individual spur lines.

3.9.2 ModbusTCP (optional)

The generators of the POWER CHARGER family can be integrated into an existing LAN network using the TCP/IP standard ModbusTCP protocol. All variants with this option support the following functions:

- 10/100 Mbit/s transmission
- DHCP protocol for setting the IP address (active by default)
- Static IP address is possible
- Cyclic retrieval of process data
- Setting and reading of the parameter set
- LED output of the network and connection status

A complete description of supported commands and assignment of process data, parameters etc. in the respective registers are available in separate files. The files are available for download on the product page Charging/High voltage generators/POWER CHARGER at www.eltex.de.



Caution!

The generator must be connected to the network by means of suitable, shielded cables; the shield must be contacted at an appropriate place on both ends. We recommend using cables of category Cat 5e or higher.

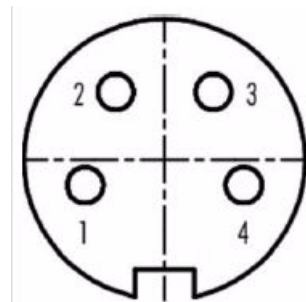

- 1 Tx +
- 2 Rx +
- 3 Tx -
- 4 Rx -

Fig. 16:
Connector
pin assignment
Plug connector
M12x1 D-coded

2 x Socket female

F00055y

3.9.3 PROFINET (optional)

The generators of the POWER CHARGER family can be integrated into an existing LAN network using the TCP/IP standard PROFINET protocol. All variants with this option support the following functions:

- 10/100 Mbit/s transmission
- DHCP protocol for setting the IP address (active by default)
- Static IP address is possible
- Cyclic retrieval of process data
- Setting and reading of the parameter set
- LED output of the network and connection status

A complete description of supported commands and assignment of process data, parameters etc. in the respective registers are available in separate files. The files are available for download on the product page Charging/High voltage generators/POWER CHARGER at www.eltex.de.



Caution!

The generator must be connected to the network by means of suitable, shielded cables; the shield must be contacted at an appropriate place on both ends. We recommend using cables of category Cat 5e or higher.

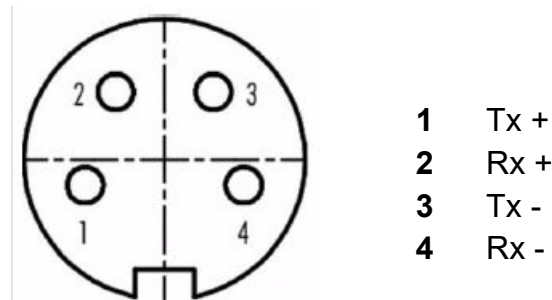

Fig. 17:
Connetor
pin assignment
Plug connector
M12x1 D-coded

2 x Socket female

F00055y

3.10 I/O Interface

3.10.1 I/O interface Charge

The I/O interface allows the generator to be integrated into a SPC or into another environment using 0...10 V or 0...20 mA interfaces.

A hardware release is required if an I/O interface is used.



Caution!

- To avoid damaging the generator, make sure that the signals are connected correctly.
- Shielded cables must be used to wire the I/O interface; the shield must make contact on both sides.
- The voltage at the individual contacts must not exceed 60 V DC.

Connector pin assignment: I/O interface

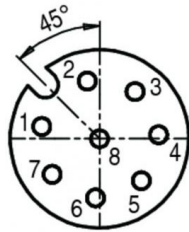

Fig. 18:
Connector pin
assignment
I/O interface
Charge

F00056y

1/2 1 Release +

wire color: white

2 Release -

wire color: brown

Insulated input high voltage release via external 24 V signal.

$U = 24 \text{ V DC } \pm 10\%$, $I < 20 \text{ mA}$



A redundant release signal is required if the generator must comply with the safety requirements of DIN EN 13849. To this end, the two signals "Release +" and "Release -" must be transmitted via separate switching paths; hardwiring of the two release signals +/- is prohibited.

3 +24 V DC Output $\pm 20\%$, $I < 50 \text{ mA}$

wire color: green

4 Fault signal output:

wire color: yellow

0 V:

The generator is not ready or has detected an error; the high voltage has been switched off.

24 V DC:

The generator is in operation and functioning properly.

24 V DC / $I < 50 \text{ mA}$

5 Actual value I

wire color: gray

0...20 mA (output):

0 mA corresponding to 0 mA output current

20 mA corresponding to 7.5 mA output current

Max. load: 500 Ω

6 Analog setpoint

wire color: pink

for setting the voltage or current setpoint (input);
see the table "Setting options" below.

7 Actual value U

wire color: blue

0...20 mA (output):

0 mA corresponding to 0 kV, 20 mA corresponding to U_{max} ;

see overview of the variants, table page 10

8 GND for max. load: 500 Ω , 24 V DC output

wire color: red

fault signals, analog setpoint and actual values

Setting options:

OFF	No change of the setpoint
Current 0 - 20 mA	20 mA correspond to the maximum output value *
Voltage 0 - 10 V	10 V correspond to the maximum output value *

* Values U_{max} resp. I_{max} see table page 11

The fault signal output can additionally be used when the limiter signal is activated; reaching a limit the display shows:

- fault signal output 0 V: limiter active
- fault signal output 24 V DC: no limiter active

3.10.2 I/O interface Discharge (optional)

The I/O interface allows the generator to be integrated into a SPC or into another environment using 0...10 V or 0...20 mA interfaces. A hardware release is required if an I/O interface is used.



Caution!

- To avoid damaging the generator, make sure that the signals are connected correctly.
- Shielded cables must be used to wire the I/O interface; the shield must make contact on both sides.
- The voltage at the individual contacts must not exceed 60 V DC.

Connector pin assignment: I/O interface

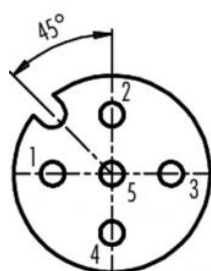

Fig. 22:
Connector pin
assignment
I/O interface
Discharge

1/4 1 Release +
wire color: white

4 Release -
wire color: yellow

Insulated input high voltage release via external 24 V signal.
 $U = 24 \text{ V DC} \pm 10\%$, $I < 20 \text{ mA}$

A redundant release signal is required if the generator must comply with the safety requirements of DIN EN 13849. To this end, the two signals "Release +" and "Release -" must be transmitted via separate switching paths; hardwiring of the two release signals +/- is prohibited.



2 +24 V DC Output $\pm 20\%$, $I < 50 \text{ mA}$
wire color: brown

3 GND for 24 V DC Output, Signal output: Pollution
wire color: green

5 Signal output: Pollution
wire color: gray
0 V:
no pollution detected
24 V DC:
pollution detected

F00052Y

3.10.3 Release circuit Discharge

Fig. 23:



Z-118005y_1

Fig. 24:

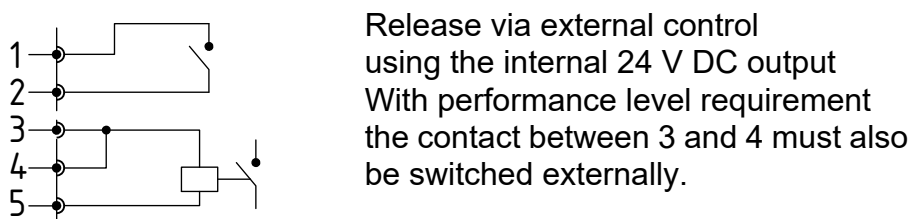

Z-118005y_2

Fig. 25:

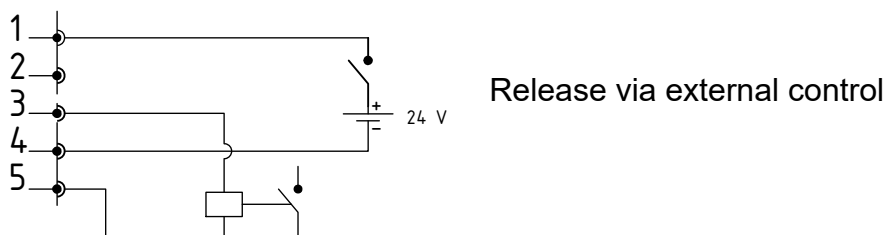

Z-118005y_2



3.11 Use of the Eltex signal cable CS and mains cable KN

When using the optional Eltex signal cable CS or the mains cable KN, the following data, the colour markings and the bending radii should be observed when connecting the individual leads.

Suitable cable variants

- **CS/A Signal cable: I/O interface Charge**
CS/AMO connection generator: straight plug
connection customer: open end
- **CS/E Signal cable I/O interface Discharge**
CS/EMO connection generator: straight plug
connection customer: open end
- **CS/C Signal cable CANopen®**
 - CS/CFFG connection generator: straight socket
connection customer: straight socket
 - CS/CFFW connection generator: straight socket
connection customer: angled socket
 - CS/CFMG connection generator: straight socket
connection customer: Stecker grade
 - CS/CFMW connection generator: straight plug
connection customer: angled plug
 - CS/CFO connection generator: straight socket
connection customer: open end
 - CS/CMFG connection generator: straight plug
connection customer: straight socket
 - CS/CMFW connection generator: straight plug
connection customer: angled socket
 - CS/CMMG connection generator: straight plug
connection customer: straight plug
 - CS/CMMW connection generator: straight plug
connection customer: angled plug
 - CS/CMO connection generator: straight plug
connection customer: open end
- **CS/C Signal cable Fieldbus Industrial Ethernet**
 - CS/IMMG connection generator: straight plug
connection customer: straight plug
 - CS/IMMW connection generator: straight plug
connection customer: angled plug
 - CS/IMR connection generator: straight plug
connection customer: RJ45 plug

- **KN/G Mains cable Supply voltage AC**
 - KN/GA connection generator: mains plug C13
connection customer: mains safety plug
 - KN/GB connection generator: mains plug C13
connection customer: mains plug Switzerland
 - KN/GD connection generator: mains plug C13
connection customer: open end
- **KN/H Mains cable Supply voltage 24 V**
 - KN/HD connection generator: straight plug
connection customer: open end

Cable assignment for connections with open end

CS/A Signal cable I/O interface Charge

Core no.	Core colour	Signal
1	white	release +
2	brown	release -
3	green	+24 V DC output
4	yellow	fault signal output
5	gray	actual value I
6	pink	analog setpoint
7	blue	actual value U
8	red	GND
	shield	ground potential

CS/E Signal cable I/O interface Discharge

Core no.	Core colour	Signal
1	white	release +
2	brown	+24 V DC output
3	green	GND
4	yellow	release -
5	gray	pollution signal output
	shirm	ground potential

CS/C Signal cable CANopen®

Core no.	Core colour	Signal
2	red	+24 V DC output (optional)
3	black	GND
4	white	CAN-H
5	blue	CAN-L
	shield	ground potential

KN/H Mains cable Supply voltage 24 V DC

Core no.	Core colour	Signal
1	white	+24 V DC
2	brown	+24 V DC
3	green	0 V
4	yellow	0 V

KN/G Mains cable Supply voltage AC

Core no.	Core colour	Signal
1	brown or black	L
2	blue or black	N
3	green / yellow	protective conductor

Bending radii

When installing the cables, observe the following minimum bending radii:

Cable	CS/A	CS/E	CS/C	CS/I
fixed	38.4 mm	34.8 mm	55.0 mm	35.0 mm
moving	96.0 mm	87.0 mm	110.0 mm	100.0 mm

Cable	KN/G	KN/H
fixed	32.4 mm	36.6 mm
moving	101.5 mm	91.5 mm

4. Operation

In all generator variants, the operating status of the device is indicated by LEDs.

Fig. 26:
Operating status indicated by illuminated LED, shown for variant PC_/_X and PC_/_P

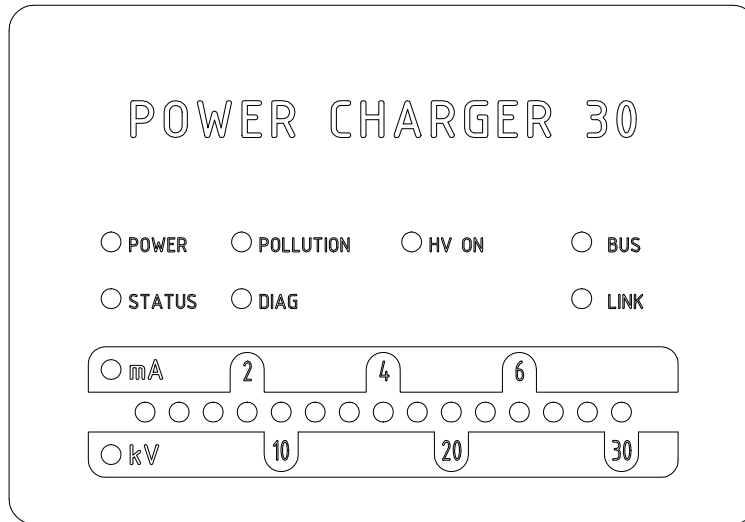
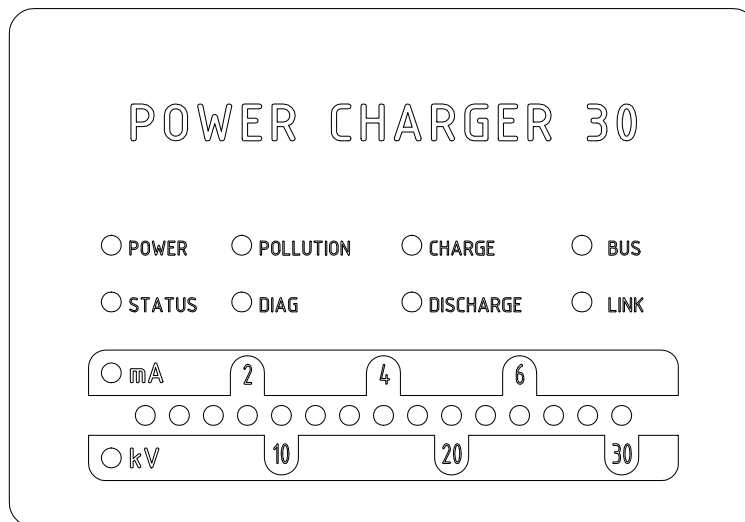

Fig. 27:
Operating status indicated by illuminated LED, shown for variant PC_/_A and PC_/_C (with active discharge)



4.1 Startup

Once all the connections and the installation have been correctly made, the system is operational and the supply voltage can be switched on.

Z-116036dy_20

Z-116036dy_3

4.2 Function monitoring

The proper function of the unit is signaled via the LEDs and the fault signal output.

- **Fault signal output**

Display of the function	State
0 V	Error / The generator is not ready for operation.
24 V	Power supply ON, no error.

- **Signal output Pollution**

only for variants with integrated active discharge

Display of the function	State
0 V	No pollution detected
24 V	Pollution detected

- **LED POWER**

LED POWER	State
OFF	Power supply OFF or power supply error
Green steady light	Power supply ON

- **Status LED:**
Display of the different operating states

Status-LED	State
Red steady light	Initializing
Red flashing	Fault
Red 1 x flashing	System fault
Green steady light	High voltage ON
Green flashing	Warning and High voltage ON
Green 1 x flashing	Generator in standy mode High voltage OFF
Green 2 x flashing	Warning and High volage OFF

- **POLLUTION LED**

POLLUTION LED	State
OFF	No pollution detected
Yellow steady light	Pollution detected

- **LED DIAGNOSIS**

DIAG LED	State
OFF	No diagnostic error detected
Red steady light	Dagnostic error detected

- **LED CHARGE**

only for variants with integrated active discharge

LED CHARGE	State
OFF	High voltage Charge OFF
Green steady light	High voltage Charge ON

- **LED DISCHARGE**

only for variants with integrated active discharge

LED DISCHARGE	State
OFF	High voltage Discharge OFF
Green steady light	High voltage Discharge ON

- **HV ON LED**

only for variants without integrated active discharge

HV ON LED	State
OFF	High voltage OFF
Green steady light	High voltage ON

- **BUS LED, LINK LED**

Indicates the status of the respective bus network. In variants without field bus support, these LEDs are permanently off.

Variants with CANopen® (optional)

Presentation of the LED outputs for the CAN bus specified under CiA 303-3.

BUS LED	State
OFF	CANopen® not initialized
Green steady light	CANopen® Device in OPERATIONAL state
Green 1 x flashing	CANopen® device in STOPPED state
Green slowly flashing (2,5 Hz)	CANopen® device in PREOPERATIONAL state
Red / Green flashing alternately (10 Hz)	Automatic baud rate recognition or LSS Service in progress
Red steady light	CAN Controller is disabled
Red 1 x flashing	Transmission of too many error frames via the CAN bus
Red 2 x flashing	CANopen® fault monitoring event
Red 3 x flashing	CANopen® Sync error
Red / Green flashing alternately (different, changing flashing durations)	CANopen® communication error, restart of the unit is necessary.

Note!

Malfunctions are not saved. The disruption of the supply voltage automatically cancels the malfunction message.

Variants with ModbusTCP (optional)

BUS LED	State
OFF	No IP address assigned
Green steady light	Modbus messages received correctly
Green flashing	Waiting for first Modbus message
Red steady light	Invalid IP address

LINK LED	State
OFF	No connection
Green steady light	100 Mbit/s connection detected
Green flashing	100 Mbit/s data interchange
Yellow steady light	10 Mbit/s connection detected
Yellow flashing	10 Mbit/s data interchange

Variants with PROFINET (optional)

BUS LED	State
OFF	Device is offline
Green steady light	Device is online and IO controller is connected in run mode
Green flashing	Analysis tool for monitoring communication connected
Green flashes 1x	Device is online and connected to IO Controller in stop mode
Red steady light	Fatal internal communication error
Red flashes 1x	Station name of the device is not set
Red flashes 2x	IP address of the device is not set
Red flashes 3x	Configuration error of the interface occurred

LINK LED	State
OFF	No connection
Green steady light	Connection is established
Green flashing	Active data transmission

- **LED BAR**

Optical indicator for the actual values of the charging voltage / charging current. Press the +/- buttons to change the setpoint using the keyboard.

The scale shows the voltage or current, depending on the selected indicator mode. It is divided into 15 segments and begins on the left with the value 0. The right end shows the maximum voltage / current. Intermediate values are indicated by a flashing LED.

When the power supply is switched on, the LED bar shows the current setpoint.

LED Bar kV	State
OFF	Charging current mode
Green steady light	Charging voltage mode
Yellow steady light	Voltage limitation active
Yellow flashing	Indication Sup Menu

LED Bar mA	State
OFF	Charging voltage mode
Green steady light	Charging current mode
Yellow steady light	Current limitation active
Yellow flashing	Indication Setup Menu

4.3 Releasing the high voltage

The release of the high voltage requires two steps:

- Hardware release, see Chapter. 3.10
- Software release as described below

Software release options

- **Automatic**
The software is released automatically once the generator has powered up.
- **Analog setpoint**
The software is released when the minimum voltage / current is exceeded; the release is canceled when the voltage / current drops below this minimum value.
- **Integrated control**
The release is enabled / disabled directly via a button (ON/OFF) of the integrated control elements.
Operating the generators with the ECC visualization system, a release for the generator set on the ECC has priority. A deactivation at the generator is not possible if the release has been set on the visualization system ECC at the same time. The generator must be deactivated via the ECC visualization system.
- **CANopen®**
The release can be enabled or disabled with the command transmitted by the CANopen® bus.
- **Ethernet based field bus**
The release can be controlled via the Ethernet-based field bus (e.g. ModbusTCP).



Caution!

Please note that for variants with active discharging and corresponding parameterization of the discharge mode as “active”, the hardware release for discharging must always **precede** the release for charging.

4.4 Integrated control elements

Settings at the high voltage generator are made via the integrated control elements. Error and warning messages can be acknowledged directly at the device.

Depending on the generator variant, the operator can use the integrated membrane keyboard or a touchscreen.

4.4.1 Using the keyboard

The keyboard is used to set certain parameters and the setpoint and to acknowledge error and warning messages.

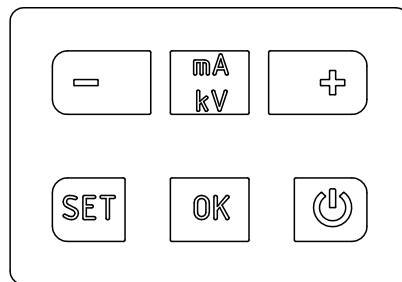

Fig. 28:
Keyboard

Z-116036ay_11

Description of buttons

- **+**
Used to change settings
- **-**
Used to change settings
- **kV / mA**
Used to change the indicator mode of the LED bar
- **Setup**
Activates the Setup Menu
- **OK**
Confirms the setting
- **ON/OFF**
Switches the high voltage output ON and OFF

Note:

When CANopen® communication is active, the key lock of the keyboard is automatically activated. To deactivate the key lock, write the corresponding parameter via the CANopen®. For further information, refer to the data sheet of the CANopen® protocol description. Also, the key lock is deactivated in the event of a communication failure. If settings on the device are necessary, this can be done by removing all CAN interface cables.

Changing the setpoint

The setpoint can be changed with the +/- buttons. Depending on the selected mode, you can change the voltage or current setpoint (voltage constant starting at 1,500 V, current constant starting at 50 μ A). The buttons can be pressed individually / pressed and held.

The setpoint can only be changed once the Setup menu has been closed.

The LED bar switches from showing the actual value to showing the setpoint. When you release the button, the bar automatically changes back to the actual value.

Changing the bar indication mode

Press the kV / mA button to switch from the high voltage indicator to the current indicator or vice versa.

The indication mode changes every time you press the button, but only if the Setup menu has been deactivated.

Switching the high voltage output ON and OFF

Press the ON/OFF button to activate or deactivate the high voltage output; the setting "Release via integrated control elements" (default setting) must be active.

Saving parameters

To save the entire parameter set, press and hold the OK button until the LEDs flash twice.

Loading the factory settings

To load the factory settings, keep the +, – and OK buttons pressed until the LEDs flash twice.

Acknowledging error / warning messages

Error and warning messages can be acknowledged with a common button combination. Press and hold the three buttons Setup, OK and kV / mA until the LEDs flash twice. The message is acknowledged following an internal system check. A successful acknowledgment is confirmed via the "Status" LED. If several errors or warnings have occurred, the message must be acknowledged several times.

Setup Menu

The Setup menu offers several setting options.

- **Discharging mode**
only for variants with integrated active discharge
passive or active discharge
- **Charging mode**
Current- or voltage-constant charging
- **Release option**
Select the desired release option
- **Analog setpoint**
Select the mode for defining the setpoint via the I/O interface
- **CANopen® node address**
Only possible in devices with an integrated CANopen® module. Set the device's node address for the CANopen® network.
- **CANopen® baud rate**
Only in devices with an integrated CANopen® module. Select the device's baud rate for the CANopen® network.

Go to the Setup menu by pressing and holding the Setup button until the LEDs light up and the two LEDs kV and mA flash yellow together. Confirm the entered settings with the OK button. The menu changes to the next item. The process cannot be canceled; you must run through the entire menu. When you exit the menu, the entered settings are saved automatically.

The currently selected item of the Setup menu is indicated by an illuminated LED in the right part of the LED bar. The left part indicates the current setting with an illuminated LED.

Fig. 29:
Image detail:
"Start setup menu "
with illuminated
mA and kV LED

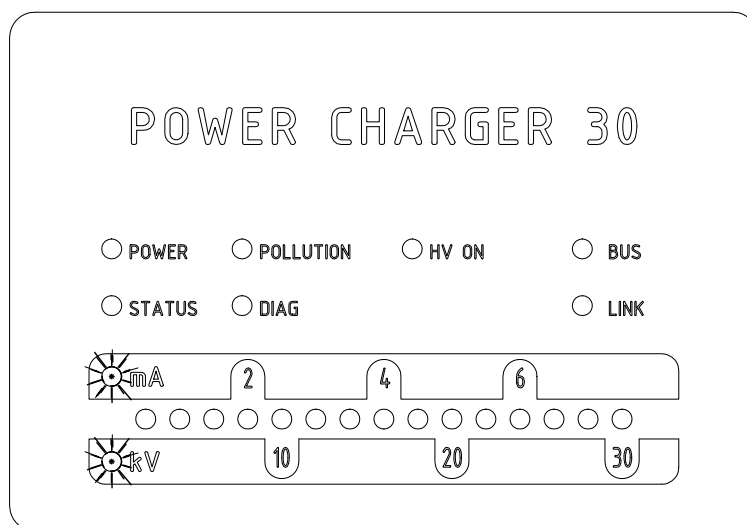
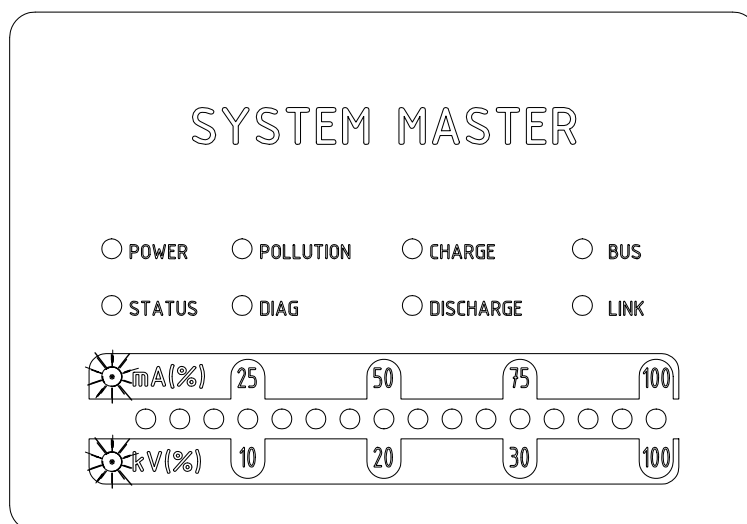

Fig. 30:
Image detail:
"Start setup menu "
with illuminated
mA and kV LED
for
"System Master"



- **Starting the Setup menu**

Press and hold the Setup button until both LEDs, kV and mA, flash yellow together. Press the OK button to go to the next setting "Operating mode".

- **Selecting the Discharge mode**
only for variants with integrated active discharge

The 10th LED from the left on the bar lights up. Use the + and - buttons to select "passive discharge" or "active discharge". The passive discharge mode is indicated by the first LED on the left, the active discharge mode by the LED to the right of it. Press the OK button to confirm the selection.

Fig. 31:
Image detail:
"passive or active discharge" with illuminated 10th LED

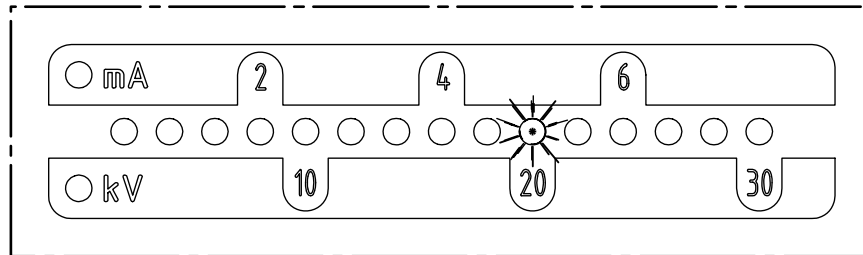

Z-116036dy_12

Fig. 32:
Image detail:
"passive or active discharge" with illuminated 10th LED for "System Master"

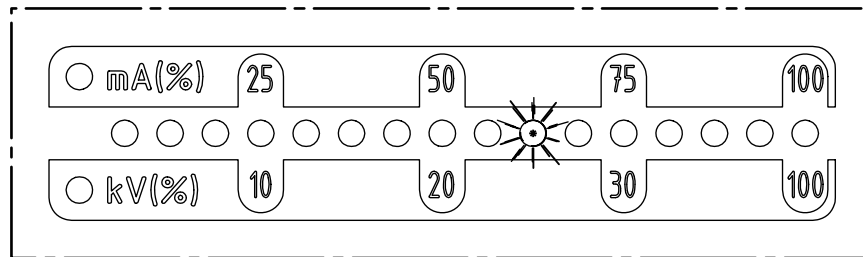

Z-116036dy_14

- **Selecting the Charge mode**

The 11th LED from the left on the bar lights up. Use the + and - buttons to select “voltage-constant” or “current-constant” charging. The voltage-constant mode is indicated by the first LED on the left, the current-constant mode by the LED to the right of it. Press the OK button to confirm the selection.

Fig. 33:
Image detail:
"voltage- or
current-constant"
with illuminated
11th LED

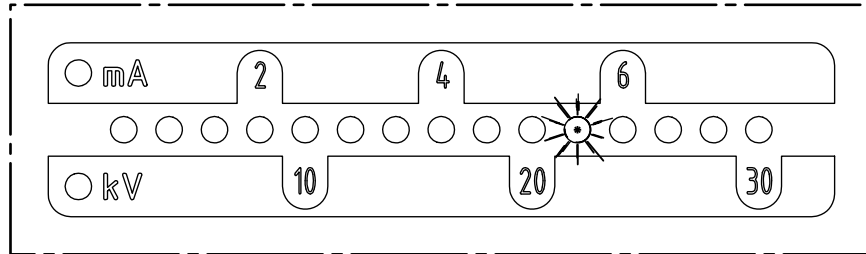

Z-116036dy_5

Fig. 34:
Image detail:
"voltage- or
current-constant"
with illuminated
11th LED for
"System Master"

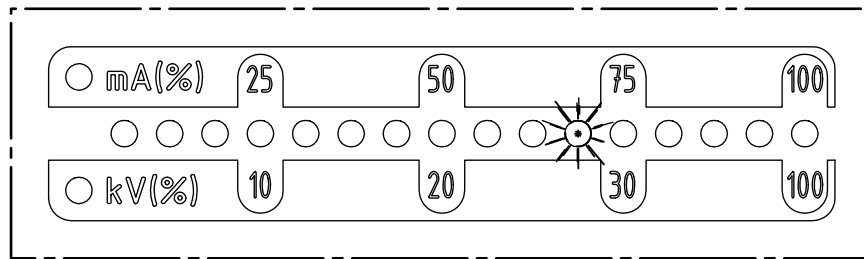

Z-116036dy_15

- **Selecting the Release options**

The 12th LED of the bar indicates the selection of the release option. The currently selected option is shown on the left. The selection can be changed with the + and - keys. Only one release option can be selected at any time. Press the OK key to confirm your selection.

LED 1: The software release has been deactivated.

LED 2: Automatic software release

LED 3: Release: analog setpoint

LED 4: Release: integrated control elements keypad button "ON/OFF"

LED 5: Release: CANopen® interface

LED 6: Release: Ethernet-based field bus interface

Fig. 35:
Image detail:
"release option"
with illuminated
12th LED

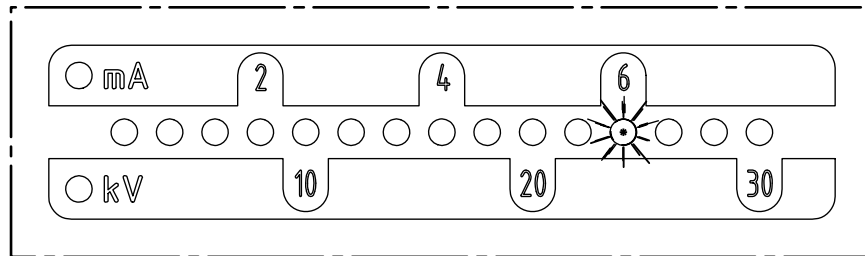

Z-116036dy_6

Fig. 36:
Image detail:
"release option"
with illuminated
12th LED
for
"System Master"

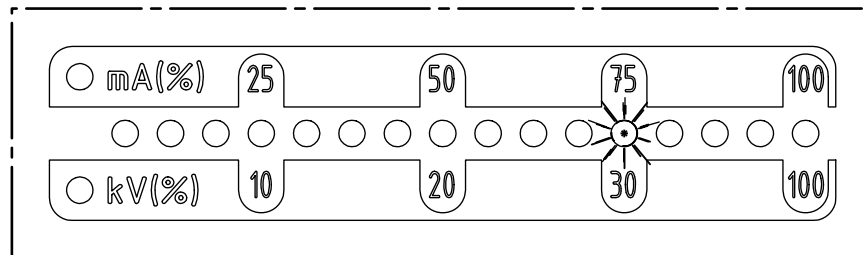

Z-116036dy_16

- **Defining the analog setpoint**

Select the mode for defining the analog setpoint. The 13th LED of the bar lights up. Use the + and - buttons to select the analog setpoint. Press the OK button to confirm your selection.

In devices with an integrated CANopen® module, the menu now goes to the item “Setting the CANopen® node address”. If the generator does not support the CANopen® interface, the next menu item is “Exit Setup”.

LED 1: Analog setpoint OFF

LED 2: Analog setpoint, current interface 0 – 20mA

LED 3: Analog setpoint, voltage interface 0 – 10V

LED 4: Analog setpoint OFF and limiter signal active

LED 5: Analog setpoint, current interface 0 – 20mA
and limiter signal active

LED 6: Analog setpoint, voltage interface 0 – 10V
and limiter signal active

Fig. 37:
Image detail:
"Defining the
analog setpoint"
with illuminated
13th LED

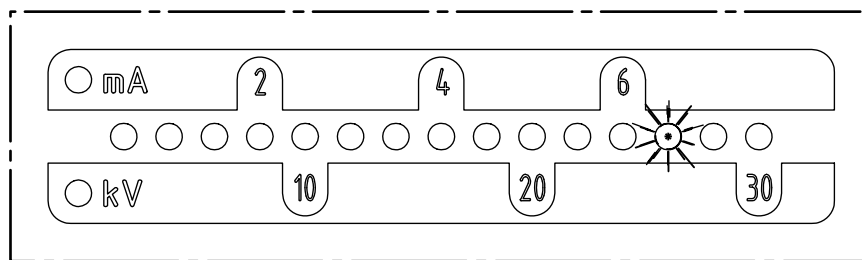

Z-116036dy_7

Fig. 38:
Image detail:
"Defining the
analog setpoint"
with illuminated
13th LED for
"System Master"

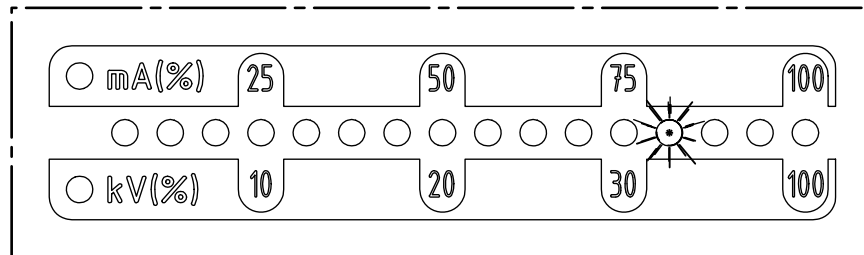

Z-116036dy_17

- **Setting the CANopen® node address**

Setting the CANopen® node address is a two-step process: first you set the tens for the address 0 –12, then the units of the address 0–9. These settings define the address as follows:

$$\text{Node address} = (\text{tens position} * 10) + \text{units position}$$

The 14th LED of the bar shows that the address is being set. The LEDs on the left indicate the current selection.

Fig. 39:
Image detail:
"Setting the
CANopen® node
address" with illu-
minated 14th LED

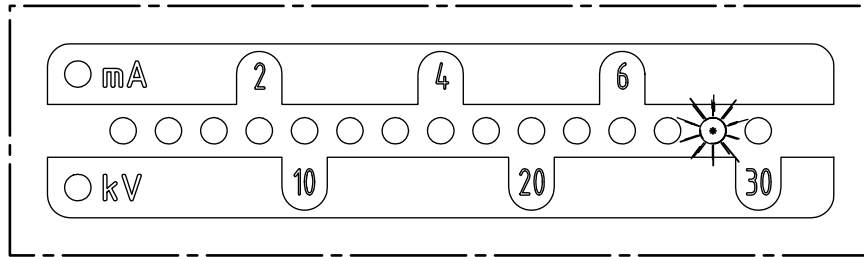

Z-116036dy_8

Fig. 40:
Image detail:
"Setting the
CANopen® node
address" with illu-
minated 14th LED
for
"System Master"

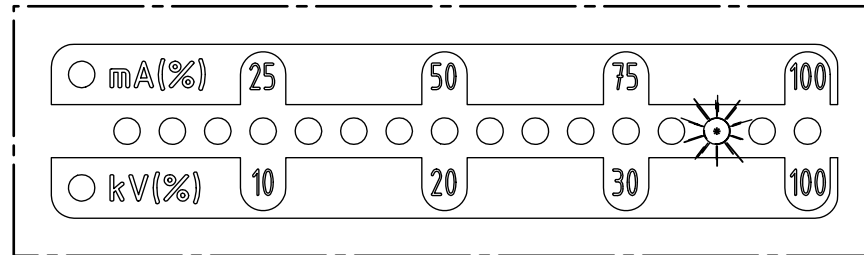

Z-116036dy_18

- **Setting the CANopen® baud rate**

The 15th LED of the bar lights up for the setting of the baud rate. The left part of the bar shows the currently selected setting. The setting can be changed with the + and - buttons. Confirm your selection with the OK button. The Setup menu automatically goes to the mode for concluding the setup. The current selection is shown by the individual LEDs:

LED 1: 1000 kBit/s

LED 2: 800 kBit/s

LED 3: 500 kBit/s

LED 4: 250 kBit/s

LED 5: 125 kBit/s

LED 6: 50 kBit/s

LED 7: 20 kBit/s

LED 8: 10 kBit/s

*Fig. 41:
Image detail:
"Setting
CANopen®
baud rate"
with illuminated
15th LED*

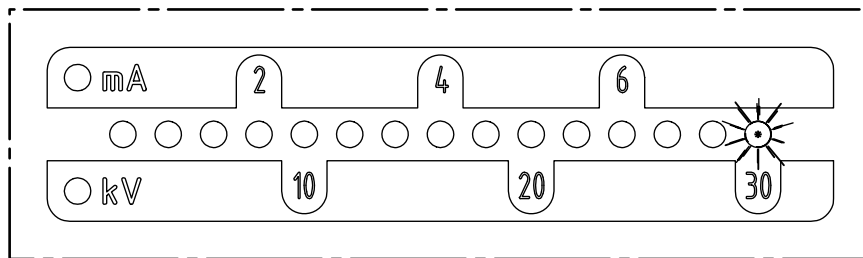

Z-116036dy_9

*Fig. 42:
Image detail:
"Setting
CANopen®
baud rate"
with illuminated
15th LED for
"System Master"*

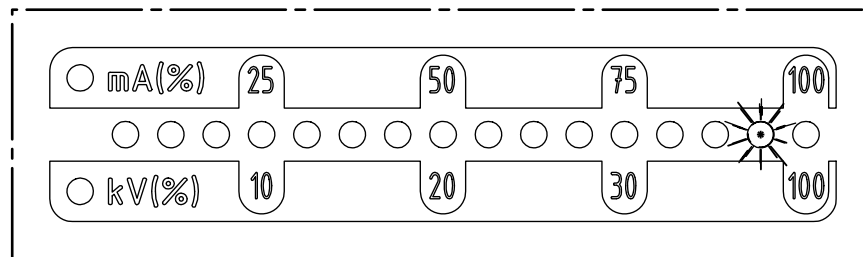

Z-116036dy_19

- **Concluding the Setup**

Press the OK button to close the Setup menu. Following an internal check, all parameters are set to their respective minimum and maximum values. Then the entire parameter set is saved. The LED bar returns to showing the actual value.

If the CANopen® node address and baud rate were set, the generator must be restarted. All other settings are applied directly after the Setup menu is closed.

4.4.2 Using the display

The following section explains the operation of the display that is integrated in the generator:

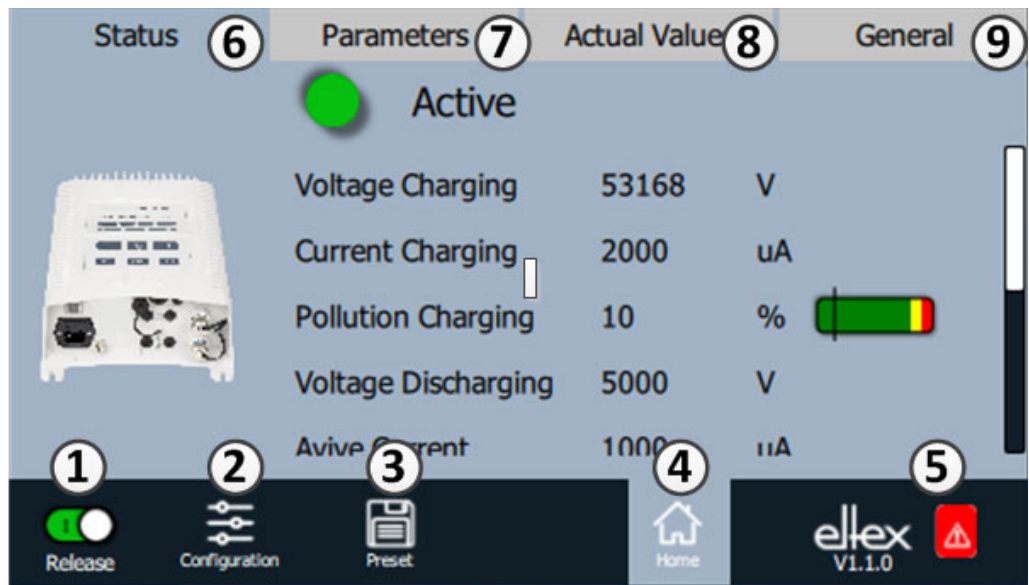

Fig. 43:
Overview of the
main menu

- 1 Release
Generator release, high voltage settings
- 2 Configuration
Settings for configuring the screen view
- 3 Presetting
Saving and loading of the presettings for generator parameterization
- 4 Main screen
Navigation to the main screen
- 5 Eltex DEBUG / message overview
Display of current error / warning messages
- 6 Status
Display of generator status information
- 7 Parameters
Display of parameters for generator setup
- 8 Actual values
Overview of available actual values for the generator
- 9 General
Display of general device information

4.4.2.1 Release

Press the "Release" button.

Slide the button in the lower left corner to the appropriate position to disable or release the high voltage. If there is a password prompt, enter the correct password.

4.4.2.2 Configuration

Press the "Configuration" button.

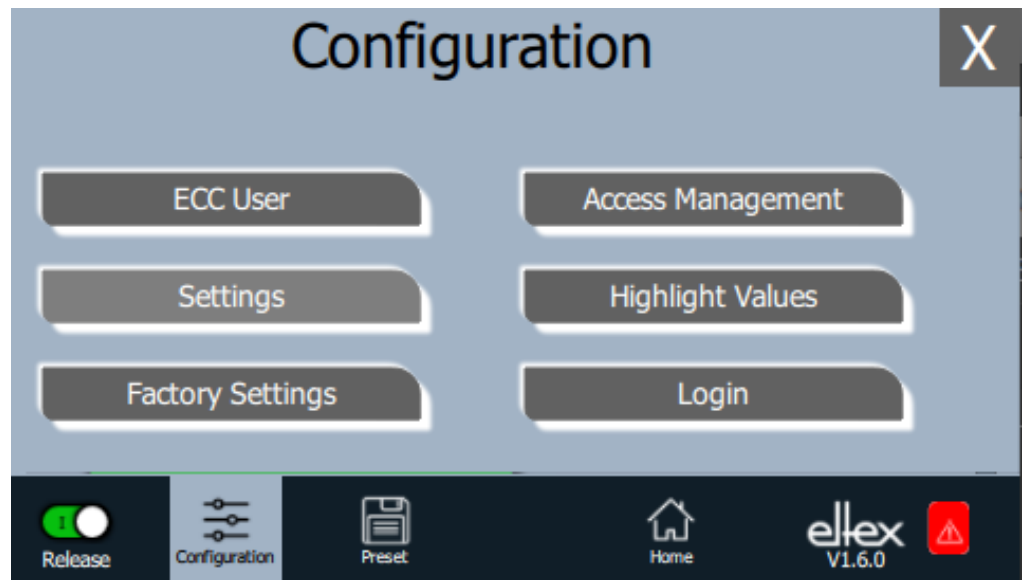

Fig. 44:
Overview of the
configuration

B00441

4.4.2.2.1 ECC User

Press the "ECC user" button.

Screen for changing passwords and user log-on / log-off.

Fig. 45:
Password

To change your password, enter the current password in the field “Current password”, then the new password in the field “New password” and again in the field “Confirm new password”; activate the new password with “Change password” and wait for the confirmation.

There are three password levels available:

- Viewer
Password: 0001
- User
Password: 2819
- Super user:
Password: 3517

4.4.2.2.2 Access Management

Press the "Access Management" button.

Screen for setting and configuring parameters for the respective user level.



Fig. 46:
Access
Management

Select the access level from the selection list of the respective parameter and confirm with OK. Press "Cancel" to cancel the changes and preserve the old settings.

4.4.2.2.3 Settings (Language, Standard access level, indication of the voltage and current values)

Press the "Settings" button.

Screen for setting the display language and the help information, setting and configuring of the parameters for the respective standard access level and display setting of the voltage and current values.

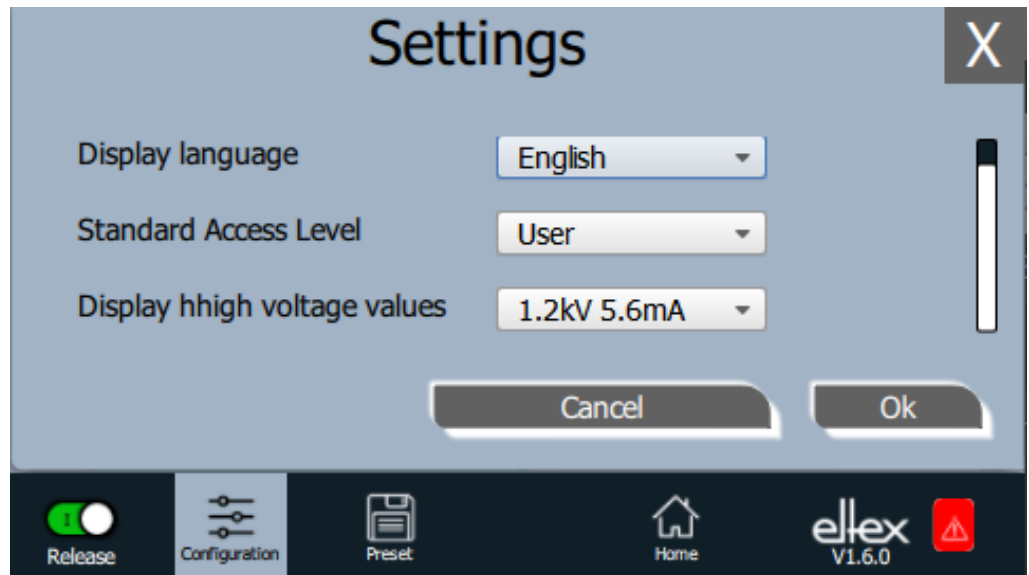

Fig. 47:
Settings

Select the desired language from the selection list and confirm with OK. Press "Cancel" to cancel the changes and preserve the old settings.

With the setting of the standard access level, the access level can be configured, which is active when the ECC visualization system is started and when the user logs off.

The voltage and currents values (actual values and parameter values) can be displayed in three different modes:

Example:

- 1.2 kV / 5.6 mA
- 1.23 kV / 5.67 mA
- 1234 V / 5678 μ A

4.4.2.2.4 Highlight Values

Press the "Highlight Values" button.

Screen for configuring the "Parameters / Status".

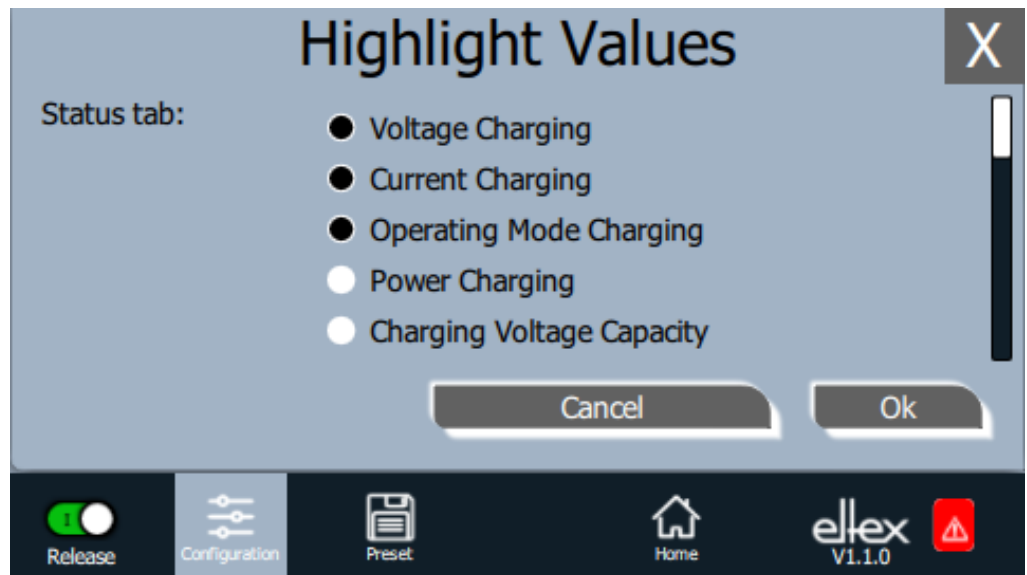

Fig. 48:
Highlight Values

Adjustable actual values are displayed based on the user's access authorization. Select the parameters and confirm with OK. Press "Cancel" to cancel the changes and preserve the old settings.

4.4.2.2.5 Factory Settings

Press the "Factory Settings" button.

When the "Factory Settings" button is pressed (see Fig. 4.4.2.2 "Configuration"), all parameters are loaded into the generator after a query and their confirmation. Press "Cancel" to cancel the changes and preserve the old settings.

4.4.2.2.6 Login

Press the "Login" button.

After pressing the "Login" button, an input mask for entering the user's password opens. After successful registration, the input mask closes automatically.

For detailed information on defining and changing the different user passwords see Chapter. 4.4.2.2.1.

4.4.2.3 Preset

Press the "Preset" button.

Screen for loading, saving, editing and deleting preset parameter sets for a quick adjustment of values to the respective operation.

The left part of the screen shows the current preset parameters, the right side the editing options.



Fig. 49:
Overview of
preset parameters

Load

The selected parameter (e.g. "Preset_0001") is loaded into the parameter set of the generator when the "Load" button is pressed.

New

The current parameter set is saved in the list of preset parameters under the name to be entered.

Change

Press "Change" for editing the selected parameter. You can change all parameters and the file name.

Delete

Press to delete the selected parameter. Pressing the "Delete" button removes the entry from the list of preset parameters.

4.4.2.4 Eltex DEBUG overview / Message overview

Press the "Eltex DEBUG" button.

View of current error and warning messages

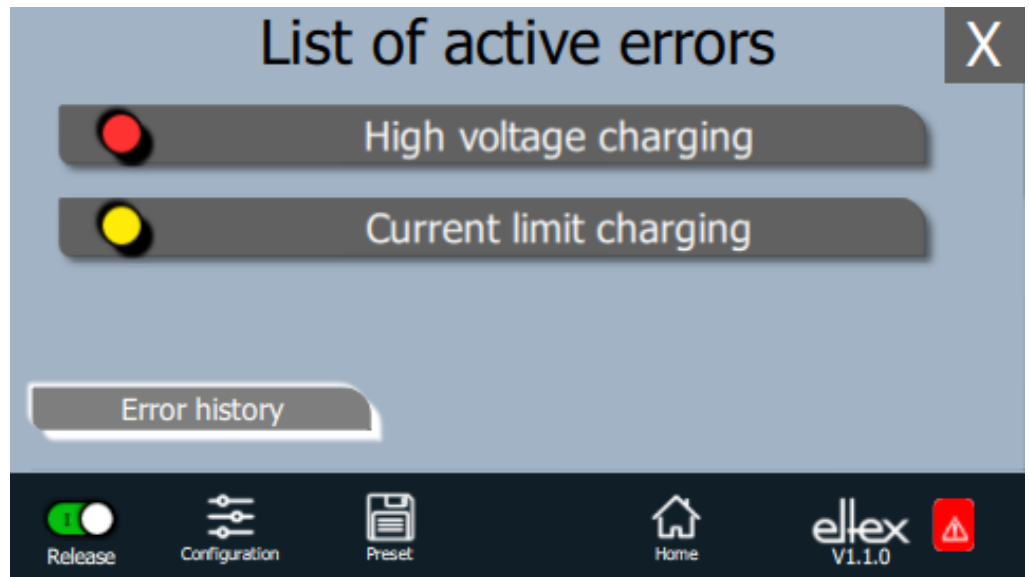

Fig. 50:
Overview
Eltex DEBUG

Pressing the "Error history" button will open a chronological list of all messages. Click on an entry to see additional information on the cause of the message and the remedy.

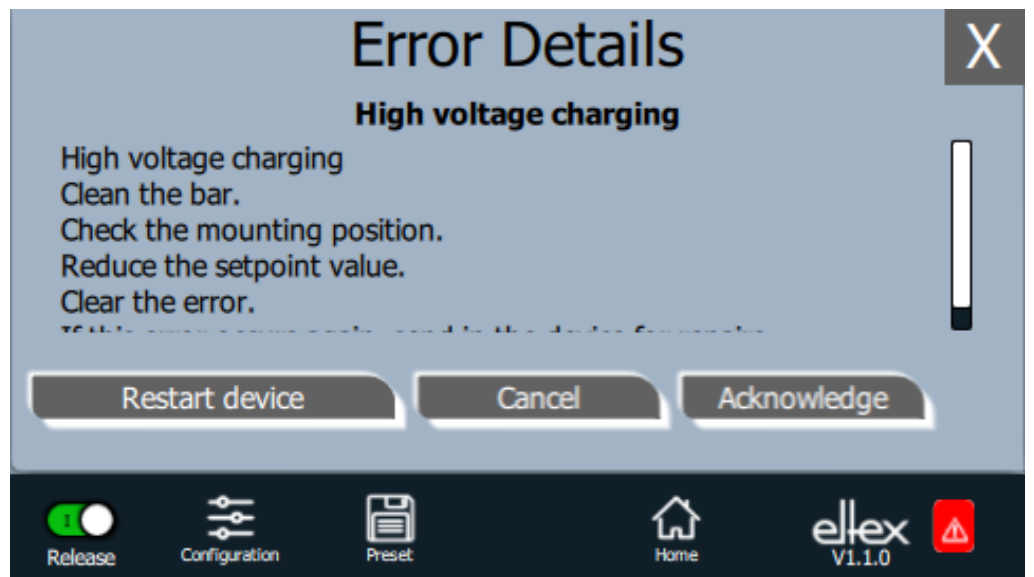

Fig. 51:
DEGUG
Overview

Pressing the "Acknowledge" button prompts an internal check; if the check is successful, the message is deleted from the list.

If there are messages that cannot be acknowledged, the generator must be restarted to rectify the error; press the "Restart device" button. Note that "diagnostic messages" cannot be acknowledged and deleted with this function. In this case, the device must be switched off, then on again.

4.4.2.5 Parameters

Press the "Parameters" button.

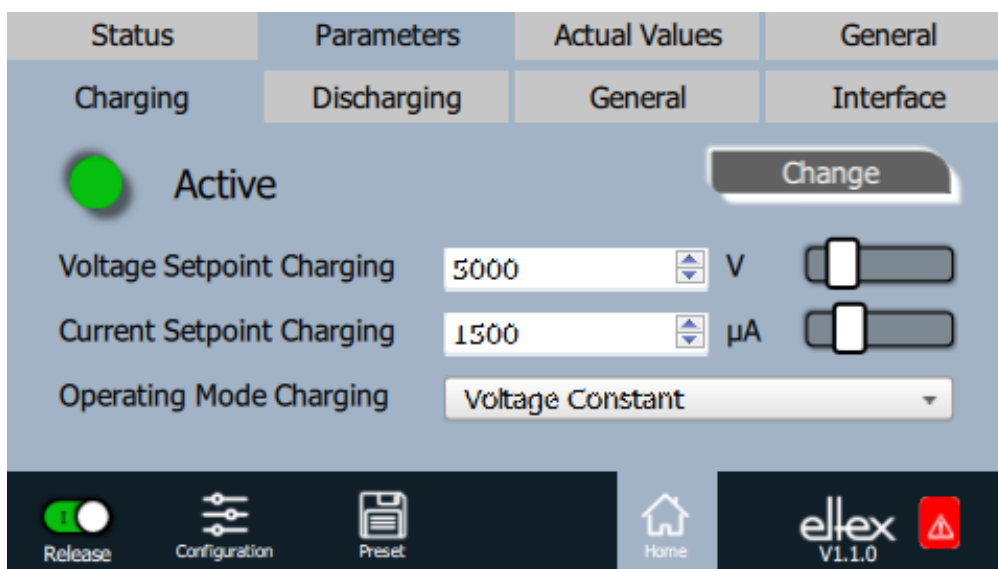

Fig. 52:
Overview of
parameters

B00344

Change the parameter value using either the slide switch or the selection list, then confirm with OK. If you do not have the required access authorization, you will have to enter a password. Select "Change all" to set all parameters that can be changed with the current access authorization; wait for the confirmation.

Note that the parameter list contains only entries that may be read with the current access authorization. Access authorizations are defined under "Configuration => Access Management".

4.4.2.6 General Parameters

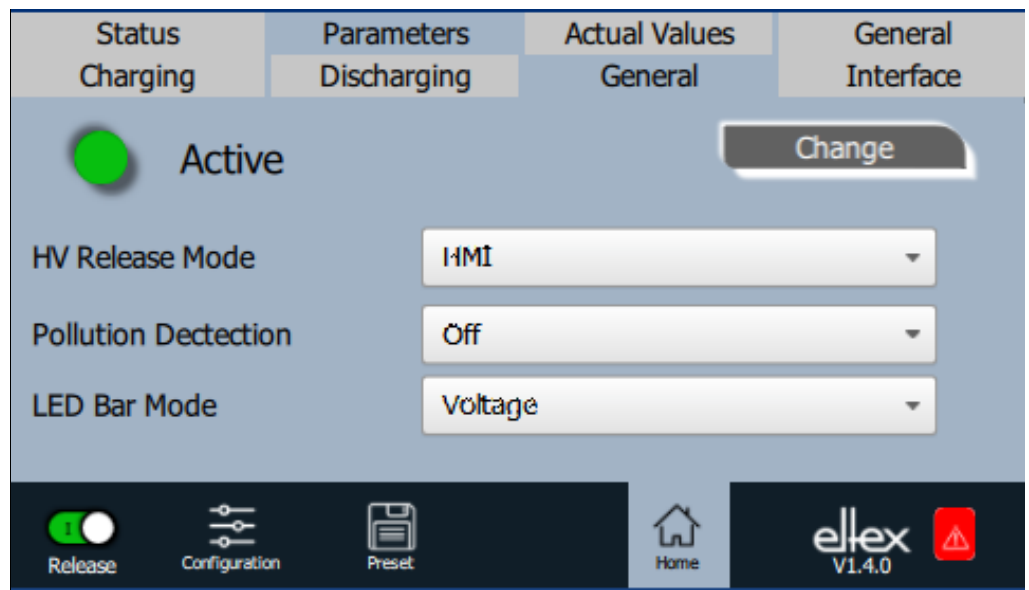

Fig. 53:
Overview of
general
parameters

For a better overview, the individual parameters are organized in several tabs. For example, the mode for high voltage release can be changed via the "General" tab. With this parameter it is possible to activate or deactivate the options for setting or blocking the high voltage release.

5. Maintenance



Warning!

Electric shock hazard!

- Do not carry out any maintenance or repair work without first disconnecting the supply voltage of the units.
- The machine which has the units fitted must not be in operation.
- Repairs and maintenance work must be carried out by qualified electricians only.

5.1 High voltage generator

The generator must be checked regularly to ensure its proper functioning. The cooling fins must be kept clean and the connections of the high voltage cables must be free of dirt and other foreign matter. The intervals for the check depend on the application and must hence be defined by the user according to the operating conditions. The generator itself does not require any maintenance.

5.2 Charging bars / Discharging bars

To ensure the proper function of the bars, clean the bars regularly depending on pollution with compressed air free of oil and water (max. 6×10^5 Pa) and a brush with soft plastic bristles.

Remove encrusted dirt (e.g. grease, adhesive, ink, etc.) from the charging bars with cleaning gasoline.

Do not immerse the bars and the high voltage cable in solvent!



Warning!

Risk of deflagration!

Wait until the solvent has evaporated before restarting the generator.



Caution!

The emission tips of the bars must not be damaged during cleaning. Brush only in lengthwise direction.

6. Troubleshooting



Warning!

Electric shock hazard!

- Do not carry out any maintenance or repair work without first switching off the high voltage and disconnecting the supply voltage.
- The machine which has the units fitted must not be in operation.
- Repairs and maintenance work must be carried out by qualified electricians.

6.1 Error messages

If a fault occurs, the high voltage will be disabled at once and the fault signal output is pulled to 0 V.

Note!

Malfunctions are not saved. The disruption of the supply voltage automatically cancels the malfunction message.

The table below shows a list of the error numbers.

Error number	Error clearable	Cause	Measure
1	No	Initialization failed	<ul style="list-style-type: none">• Interrupt the supply voltage.• If this error occurs again, send in the device for repairs.
2	No	CPU clock faulty	<ul style="list-style-type: none">• Interrupt the supply voltage.• If this error occurs again, send in the device for repairs.
3	No	Invalid high voltage configuration	<ul style="list-style-type: none">• Interrupt the supply voltage.• If this error occurs again, send in the device for repairs.
4	No	Invalid interface configuration	<ul style="list-style-type: none">• Interrupt the supply voltage.• If this error occurs again, send in the device for repairs.
5	No	Invalid error number	<ul style="list-style-type: none">• Interrupt the supply voltage.• If this error occurs again, send in the device for repairs.
6	No	Invalid error status	<ul style="list-style-type: none">• Interrupt the supply voltage.• If this error occurs again, send in the device for repairs.

Error number	Error clearable	Cause	Measure
7	No	Invalid warning number	<ul style="list-style-type: none"> • Interrupt the supply voltage. • If this error occurs again, send in the device for repairs.
8	No	Invalid warning status	<ul style="list-style-type: none"> • Interrupt the supply voltage. • If this error occurs again, send in the device for repairs.
9	No	Invalid lock of the output stages	<ul style="list-style-type: none"> • Interrupt the supply voltage. • If this error occurs again, send in the device for repairs.
10	No	Invalid system status	<ul style="list-style-type: none"> • Interrupt the supply voltage. • If this error occurs again, send in the device for repairs.
11	No	Invalid calibration data	<ul style="list-style-type: none"> • Interrupt the supply voltage. • If this error occurs again, send in the device for repairs.
13	No	Error in the logging operating data	<ul style="list-style-type: none"> • Interrupt the supply voltage. • If this error occurs again, send in the device for repairs.
14	No	Invalid parameter data	<ul style="list-style-type: none"> • Interrupt the supply voltage. • If this error occurs again, send in the device for repairs.
15	No	Invalid operating mode	<ul style="list-style-type: none"> • Interrupt the supply voltage. • If this error occurs again, send in the device for repairs.
16	No	Invalid command parameter access	<ul style="list-style-type: none"> • Interrupt the supply voltage. • If this error occurs again, send in the device for repairs.
17	No	Invalid application status	<ul style="list-style-type: none"> • Interrupt the supply voltage. • If this error occurs again, send in the device for repairs.
18	No	Invalid data block	<ul style="list-style-type: none"> • Interrupt the supply voltage. • If this error occurs again, send in the device for repairs.
19	No	Invalid data position	<ul style="list-style-type: none"> • Interrupt the supply voltage. • If this error occurs again, send in the device for repairs.

Error number	Error clearable	Cause	Measure
22	Yes	24 V DC Supply faulty	<ul style="list-style-type: none"> • Check the 24 V DC supply. • Interrupt the supply voltage. • If this error occurs again, send in the device for repairs.
23	Yes	Overcurrent supply voltage	<ul style="list-style-type: none"> • Check the 24 V DC supply. • Clear the error. • If this error occurs again, send in the device for repairs.
24	Yes	High voltage charging	<ul style="list-style-type: none"> • Clean the bar. • Check the mounting position. • Reduce the setpoint value. • Clear the error. • If this error occurs again, send in the device for repairs.
29	Yes	Current high voltage charging	<ul style="list-style-type: none"> • Clean the bar. • Check the mounting position. • Reduce the setpoint value. • Clear the error. • If this error occurs again, send in the device for repairs.
32	Yes	Power high voltage charging	<ul style="list-style-type: none"> • Clean the bar. • Check the mounting position. • Reduce the setpoint value. • Clear the error. • If this error occurs again, send in the device for repairs.
35	Yes	Lock of the high voltage has failed	<ul style="list-style-type: none"> • Interrupt the supply voltage. • If this error occurs again, send in the device for repairs.
36	Yes	Setpoint setting has failed	<ul style="list-style-type: none"> • Interrupt the supply voltage. • If this error occurs again, send in the device for repairs.
37	Yes	Invalid release status	<ul style="list-style-type: none"> • Check the release switching of the high voltage. • Clear the error. • If this error occurs again, send in the device for repairs.

Error number	Error clearable	Cause	Measure
40	Yes	Pollution bar charging	<ul style="list-style-type: none"> • Clean the bar. • Check the mounting position. • Reduce the setpoint value. • Clear the error. • If this error occurs again, send in the device for repairs.
42	Yes	General memory	<ul style="list-style-type: none"> • Clear the error. • If this error occurs again, send in the device for repairs.
43	Yes	Read access memory	<ul style="list-style-type: none"> • Clear the error. • If this error occurs again, send in the device for repairs.
44	Yes	Write access memory	<ul style="list-style-type: none"> • Clear the error. • If this error occurs again, send in the device for repairs.
45	Yes	Invalid parameter address	<ul style="list-style-type: none"> • Interrupt the supply voltage. • If this error occurs again, send in the device for repairs.
48	Yes	Fault signal output	<ul style="list-style-type: none"> • Clear the error. • If this error occurs again, send in the device for repairs.
49	Yes	LEDs	<ul style="list-style-type: none"> • Clear the error. • If this error occurs again, send in the device for repairs.
50	Yes	I/O interface	<ul style="list-style-type: none"> • Check the connection of the I/O interface. • Check the voltages at the interface. • Clear the error. • If this error occurs again, send in the device for repairs.
51	Yes	Keyboard	<ul style="list-style-type: none"> • Clear the error. • If this error occurs again, send in the device for repairs.
52	Yes	PID controller	<ul style="list-style-type: none"> • Clear the error. • If this error occurs again, send in the device for repairs.

Error number	Error clearable	Cause	Measure
53	Yes	Range PID controller	<ul style="list-style-type: none"> • Clear the error. • If this error occurs again, send in the device for repairs.
54	Yes	Setpoint ramp	<ul style="list-style-type: none"> • Clear the error. • If this error occurs again, send in the device for repairs.
55	Yes	Flash count of hard flashes, limit exceeded	<ul style="list-style-type: none"> • Clean the bar. • Check the mounting position. • Reduce the setpoint value. • Clear the error. • If this error occurs again, send in the device for repairs.
56	Yes	Flash count of soft flashes, limit exceeded	<ul style="list-style-type: none"> • Clean the bar. • Check the mounting position. • Reduce the setpoint value. • Clear the error. • If this error occurs again, send in the device for repairs.
57	Yes	Temperature	<ul style="list-style-type: none"> • Check the installation of the generator. • Improve the cooling of the housing. • Reduce the ambient temperature. • Reduce the setpoint value. • Clear the error. • If this error occurs again, send in the device for repairs.
58	Yes	High voltage Discharging	<ul style="list-style-type: none"> • Clean the bar. • Check the mounting position. • Reduce the setpoint value. • Clear the error. • If this error occurs again, send in the device for repairs.
59	Yes	Current High voltage Discharging	<ul style="list-style-type: none"> • Clean the bar. • Check the mounting position. • Reduce the setpoint value. • Clear the error. • If this error occurs again, send in the device for repairs.

Error number	Error clearable	Cause	Measure
60	Yes	Short circuit High voltage Charging	<ul style="list-style-type: none"> • Clean the bar. • Check the mounting position. • Reduce the setpoint value. • Clear the error. • If this error occurs again, send in the device for repairs.
61	Yes	Power High voltage Discharging	<ul style="list-style-type: none"> • Clean the bar. • Check the mounting position. • Reduce the setpoint value. • Clear the error. • If this error occurs again, send in the device for repairs.
62	Yes	Discharging bar 1	<ul style="list-style-type: none"> • Check the connection of the bar. • Check the settings. • Clear the error. • If this error occurs again, send in the device for repairs.
63	Yes	Discharging bar 2	<ul style="list-style-type: none"> • Check the connection of the bar. • Check the settings. • Clear the error. • If this error occurs again, send in the device for repairs.
73	Yes	General error ethernet modul	<ul style="list-style-type: none"> • Check the bus line. • Check the communication with the control. • Clear the error. • If this error occurs again, send in the device for repairs.
74	Yes	Communication error ethernet modul	<ul style="list-style-type: none"> • Check the bus line. • Check the communication with the control. • Clear the error. • If this error occurs again, send in the device for repairs.
76	Yes	Invalid operating mode ethernet modul	<ul style="list-style-type: none"> • Check the bus line • Check the communication with the control. • Clear the error. • If this error occurs again, send in the device for repairs.

Error number	Error clearable	Cause	Measure
81	No	Diagnostic error: error in the error management of the diagnosis	<ul style="list-style-type: none"> • Interrupt the supply voltage. • If this error occurs again, send in the device for repairs.
82	No	Diagnostic error: invalid state of the diagnosis	<ul style="list-style-type: none"> • Interrupt the supply voltage. • If this error occurs again, send in the device for repairs.
83	No	Diagnostic error: initialization of the diagnosis has failed	<ul style="list-style-type: none"> • Interrupt the supply voltage. • If this error occurs again, send in the device for repairs.
84	Nein	Diagnostic error: ground connection is faulty	<ul style="list-style-type: none"> • Interrupt the supply voltage. • If this error occurs again, send in the device for repairs.
85	No	Diagnostic error: supply voltage ist faulty.	<ul style="list-style-type: none"> • Interrupt and check the supply voltage. • If this error occurs again, send in the device for repairs.
86	No	Diagnostic error: overvoltage channel 1 charging	<ul style="list-style-type: none"> • Interrupt the supply voltage. • Clean the bar. • Reduce the setpoint value. • If this error occurs again, send in the device for repairs.
87	No	Diagnostic error: overvoltage Channel 2 charging	<ul style="list-style-type: none"> • Interrupt the supply voltage. • Clean the bar. • Reduce the setpoint value. • If this error occurs again, send in the device for repairs.
88	No	Diagnostic error: monitoring of the DC link voltage	<ul style="list-style-type: none"> • Interrupt the supply voltage. • Check the setpoint. • Check the bar. • If this error occurs again, send in the device for repairs.
89	No	Diagnostic error: monitoring of the power stage	<ul style="list-style-type: none"> • Interrupt the supply voltage. • Check the setpoint. • Check the bar. • If this error occurs again, send in the device for repairs.

Error number	Error clearable	Cause	Measure
90	No	Diagnostic error: hardware release channel 1 charging	<ul style="list-style-type: none"> • Interrupt the supply voltage. • Check the release switching. • If this error occurs again, send in the device for repairs.
91	No	Diagnostic error: hardware release channel 2 charging	<ul style="list-style-type: none"> • Interrupt the supply voltage. • Check the release switching. • If this error occurs again, send in the device for repairs.
92	No	Diagnostic error: software release charging	<ul style="list-style-type: none"> • Interrupt the supply voltage. • Check the release switching. • If this error occurs again, send in the device for repairs.
93	No	Diagnostic error: release charging inconsistent	<ul style="list-style-type: none"> • Interrupt the supply voltage. • Check the connection of the bar. • If this error occurs again, send in the device for repairs.
96	No	Diagnostic error: monitoring discharging channel 1	<ul style="list-style-type: none"> • Interrupt the supply voltage. • Check the connection of the bar. • If this error occurs again, send in the device for repairs.
97	No	Diagnostic error: monitoring discharging channel 2	<ul style="list-style-type: none"> • Interrupt the supply voltage. • Check the connection of the bar. • If this error occurs again, send in the device for repairs.
98	No	Diagnostic error: monitoring high voltage discharging	<ul style="list-style-type: none"> • Interrupt the supply voltage. • If this error occurs again, send in the device for repairs.
99	No	Diagnostic error: overvoltage channel 1 discharging	<ul style="list-style-type: none"> • Interrupt the supply voltage. • Clean the bar. • If this error occurs again, send in the device for repairs.
100	No	Diagnostic error: overvoltage channel 2 discharging	<ul style="list-style-type: none"> • Interrupt the supply voltage. • Clean the bar. • If this error occurs again, send in the device for repairs.

Error number	Error clearable	Cause	Measure
103	No	Diagnostic error: hardware release channel 1 discharging	<ul style="list-style-type: none"> • Interrupt the supply voltage. • Check the release switching.. • If this error occurs again, send in the device for repairs.
104	Nein	Diagnostic error: hardware release channel 2 discharging	<ul style="list-style-type: none"> • Interrupt the supply voltage. • Check the release switching.. • If this error occurs again, send in the device for repairs.
105	Nein	Diagnostic error: software release discharging	<ul style="list-style-type: none"> • Interrupt the supply voltage. • Check the release switching.. • If this error occurs again, send in the device for repairs.
106	Nein	Diagnostic error: release discharging inconsistent	<ul style="list-style-type: none"> • Interrupt the supply voltage. • Check the release switching.. • If this error occurs again, send in the device for repairs.

6.2 Warning messages

If a warning message appears, the output of the high voltage will not be disrupted.

Note!

Warning messages are not saved. The disruption of the supply voltage automatically cancels the warning message.

The table below shows a list of the warning numbers.

Warning number	Cause	Measure
1	Error cannot be cleared.	<ul style="list-style-type: none"> Interrupt the supply voltage. If this error occurs again, send in the device for repairs.
2	Clearable error has not occurred.	<ul style="list-style-type: none"> Clear the warning.
3	Invalid error counter	<ul style="list-style-type: none"> Clear the warning.
4	The release of the output stage has been disabled.	<ul style="list-style-type: none"> An error occurred during the release of the high voltage. Do not send the release telegram again. First eliminate the cause of the error, then clear the warning.
7	Battery voltage too low	<ul style="list-style-type: none"> Change the integrated battery; see discription Chap. 11. Change must be carried out by qualified personnel.
8	Flash count of hard flashes, limit exceeded	<ul style="list-style-type: none"> Clean the bar. Check the mounting position. Reduce the setpoint value.
9	Flash count of soft flashes, limit exceeded	<ul style="list-style-type: none"> Clean the bar. Check the mounting position. Reduce the setpoint value.
16	Current limit charging	<ul style="list-style-type: none"> Clean the bar. Check the mounting position. Reduce the setpoint value.
17	Voltage limit charging	<ul style="list-style-type: none"> Clean the bar. Check the mounting position. Reduce the setpoint value.
23	Pollution of the bar charging	<ul style="list-style-type: none"> Clean the bar.

Warning number	Cause	Measure
24	Power limit charging	<ul style="list-style-type: none"> • Clean the bar. • Check the mounting position. • Reduce the setpoint value.
26	Temperature	<ul style="list-style-type: none"> • Check the installation of the generator. • Improve the cooling of the housing. • Reduce the ambient temperature. • Reduce the setpoint value.
27	Voltage limit discharging	<ul style="list-style-type: none"> • Clean the bar. • Check the mounting position.
28	Current limit discharging	<ul style="list-style-type: none"> • Clean the bar. • Check the mounting position.
29	Power limit discharging	<ul style="list-style-type: none"> • Clean the bar. • Check the mounting position. • Reduce the setpoint value. • Reduce the power input. • Reduce the discharge frequency.
64	CAN communication error	<ul style="list-style-type: none"> • Check bus cabling. • Check baud rate. • Clear the warning. • If this warning occurs again, send in the device for repairs.
65	General CANopen® communication error	<ul style="list-style-type: none"> • Check bus cabling. • Check CANopen® - transmission. • Clear the warning. • If this warning occurs again, send in the device for repairs.
66	CANopen® SDO access	<ul style="list-style-type: none"> • Check SDO transmission protocol. • Clear the warning. • If this warning occurs again, send in the device for repairs.
67	CANopen® PDO access	<ul style="list-style-type: none"> • Check PDO transmission protocol. • Compare PDO access with the EDS file. • Clear the warning. • If this error occurs again, send in the device for repairs.

Warning number	Cause	Measure
68	CANopen® PDO data length is faulty	<ul style="list-style-type: none"> • Check PDO transmission protocol. • Clear the warning. • If this warning occurs again, send in the device for repairs.
69	CANopen® buffer overflow	<ul style="list-style-type: none"> • Bus load is too high. • Too many CAN messages have been sent. • Clear the warning. • If this warning occurs again, send in the device for repairs.
70	CANopen® error field transmission error	<ul style="list-style-type: none"> • Clear the warning. • If this warning occurs again, send in the device for repairs.
71	CANopen® node monitoring error	<ul style="list-style-type: none"> • Check node monitoring of the CANopen® master. • Clear the warning. • If this warning occurs again, send in the device for repairs.
72	Error during re-connection	<ul style="list-style-type: none"> • Check bus cabling. • Check baud rate. • Clear the warning. • If this warning occurs again, send in the device for repairs.
81	Parameter value below minimum	<ul style="list-style-type: none"> • Parameter was automatically corrected to minimum. • Clear the warning.
82	Parameter value above maximum	<ul style="list-style-type: none"> • Parameter was automatically corrected to maximum. • Clear the warning.
84	Invalid parameter value	<ul style="list-style-type: none"> • Parameter was not changed. Transmit correct value. • Clear the warning.

7. Technical Specifications POWER CHARGER PC__

Power ratings	
Supply Voltage	PC__/_/_L: 24 V DC \pm 15 %, 100 W PC__/_/_S: 90 - 264 V AC, 47 - 63 Hz, 100 W PC__/_/_H: 90 - 264 V AC, 47 - 63 Hz, 200 W The voltage at the input plugs of the 24 V DC supply voltage, the I/O interfaces for charging and discharging and the field bus interfaces must not exceed 60 V DC.
Inrush current	max. 25 A
Output voltage	Charge: U_{\min} - U_{\max} see table page 11 Discharge: 3,5 - 5 kV AC, 50 - 250 Hz adjustable: depending on device variant
Output current	Charge: I_{\min} - I_{\max} see table page 11 Discharge: max. 6.2 mA (depending on device variant)
Operating mode	Current constant resp. Voltage constant
Enclosure	Aluminum coated
Protection class	IP54 according EN 60529
Ambient operating temperature	+5...+50 °C (+41...+122 °F)
Storage temperature	-20...+80 °C (-4...+176 °F)
Ambient Humidity	max. 80 % r.h. non-condensing
Dimensions with wall bracket	106 x 232 x 394 mm (H x W x D)
Weight	max. 8 kg (depending on device variant)
UL Approval	File No. E227156
Performance Level d Approval	depending on device variant see nameplate
Release	The requirements for PELV (Protective Extra Low Voltage) or SELV (Safety Extra Low Voltage) must be fulfilled.

<p>Connections, interfaces</p> <p>High voltage output</p> <p>I/O interface</p>	<p>2 high voltage connections for the direct connection of two consumers</p> <p>Floating input for external high voltage release (24 V DC) Input setpoint: 0...10 V resp. 0 - 20 mA Output actual value: 0...20 mA Fault signal output: max. 24 V DC \pm20 % / 50 mA internal protection 24 V DC-output: max. 24 V DC \pm20 % / 50 mA) internal protection</p>
<p>Connections, interfaces (optional)</p> <p>CANopen®</p> <p>ModbusTCP</p>	<p>supported baud rates: 10 kBit/s, 20 kBit/s, 50 kBit/s, 125 kBit/s, 250 kBit/s, 500 kBit/s, 800 kBit/s, 1000 kBit/s</p> <p>supported transmission rates: 10 / 100 MBit/s</p>

as shown on
appliance
marking:



Guaranteed safety characteristics for generator variants with performance level d

PC__ / _____ P und PC__ / _____ D

High voltage generator POWER CHARGER			
Safety-related parameters according EN ISO 13849			
	SF1 (Charging)	SF2 (Discharging)	SF1 + SF2 (total)
Category	Cat 3	Cat 3	Cat 3
Performance Level	PL d	PL d	PL d
PFH resp. PFHd	2.06E-09 / h	1.51E-09 / h	4.44E-09 / h

Safety function according to Performance Level

Safety function 1 (SF1)

The charging voltage must only be generated if

- it is requested by the control system and
- the ground monitor of the discharging bar has not signaled an error and
- there is no overvoltage at the charging bar

Safety function 2 (SF2)

The discharging voltage must only be generated if

- it is requested by the control system and
- the ground monitor of the discharging bar has not signaled an error and
- there is no overvoltage at the charging bar

8. Dimensions

8.1 High voltage generator POWER CHARGER

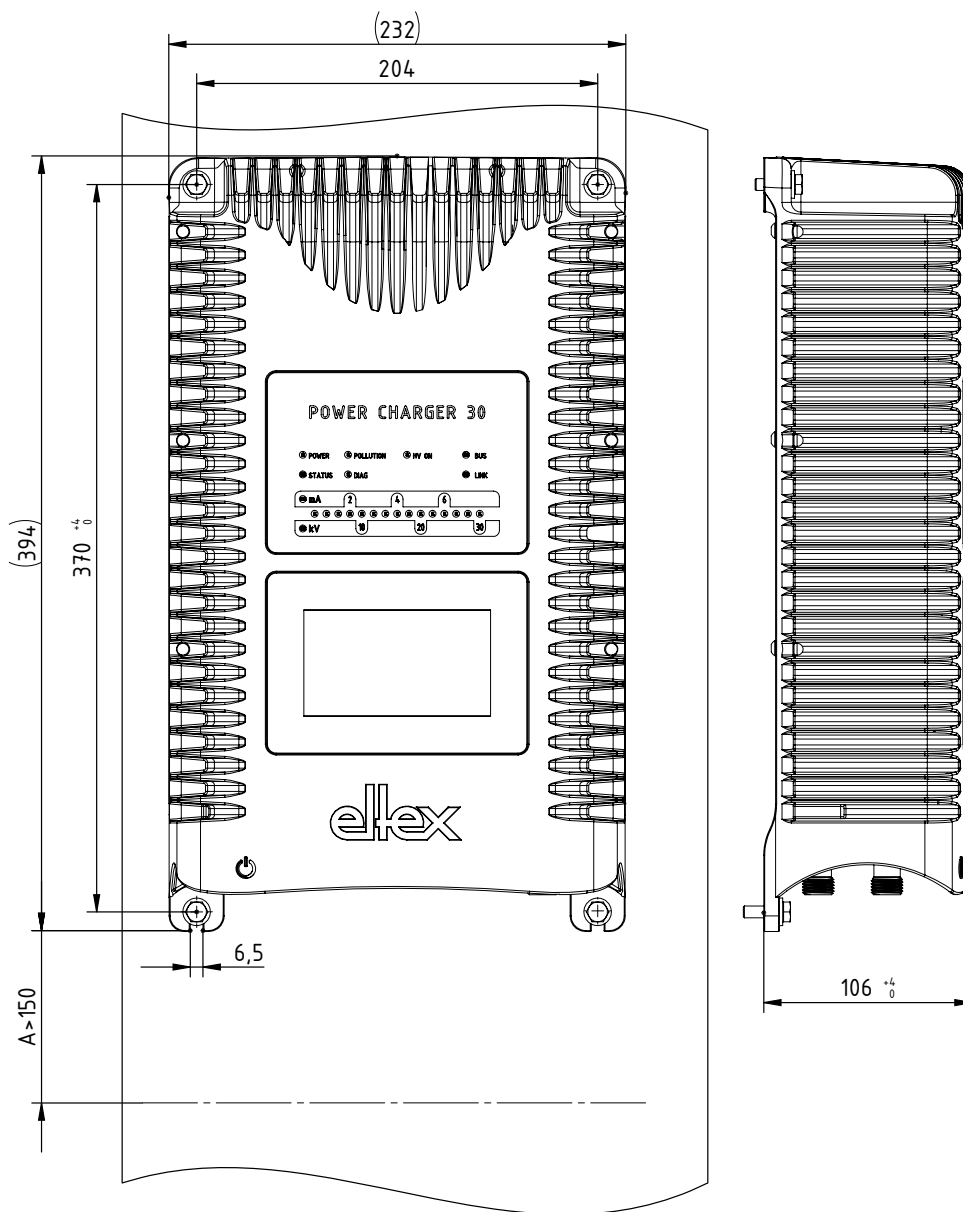

Fig. 54:
Dimensions
High voltage
generator with
fixing positions

Assembly with 4 x hexagon screws M5 (alternatively M6) including flat washer

Z-116036dy_1

8.2 Distributor PCV / PCV6 (optional)

8.2.1 Distributor PCV (max. 30 kV)

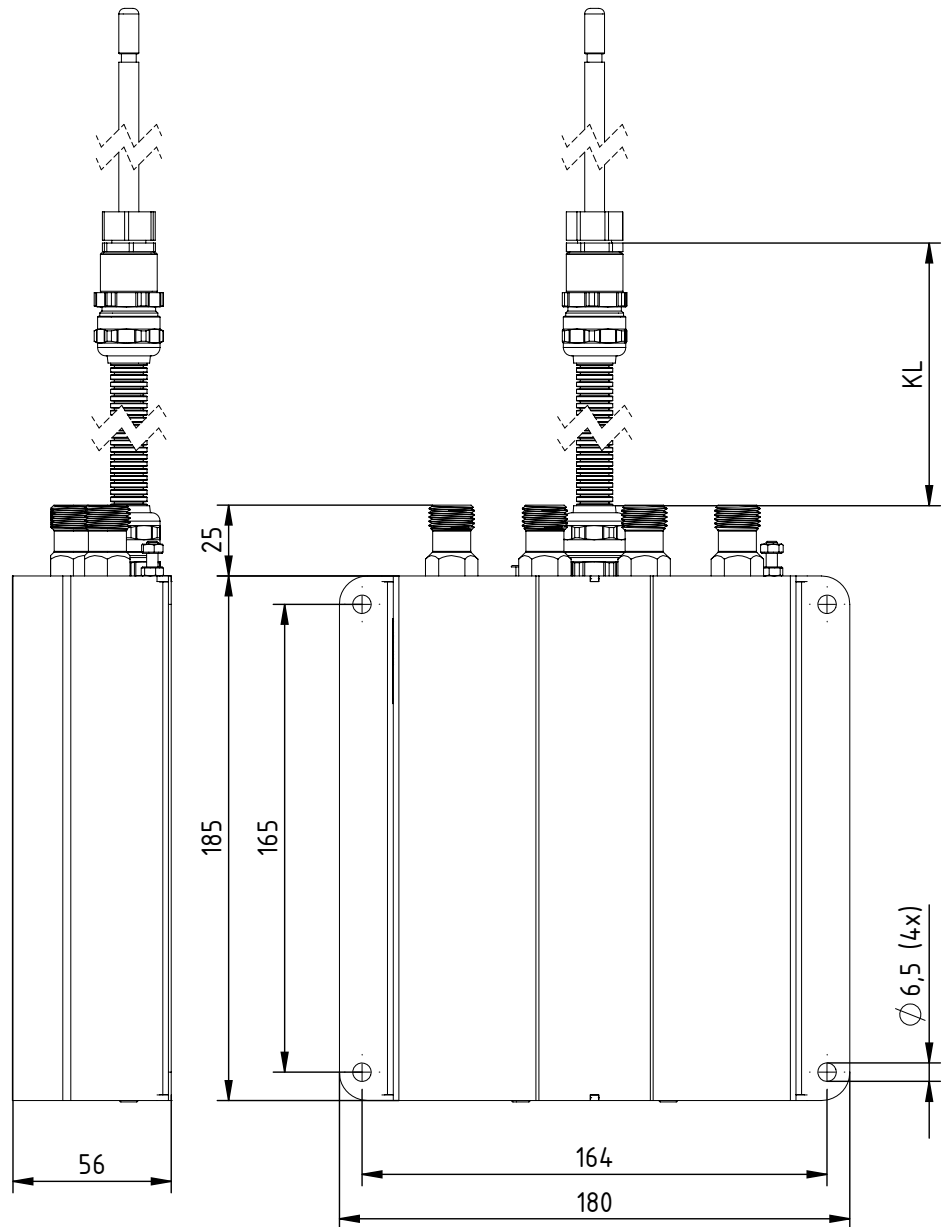

Fig. 55:
Dimensions
Distributor
PCV/2, PCV/4

Z-117457ay_2

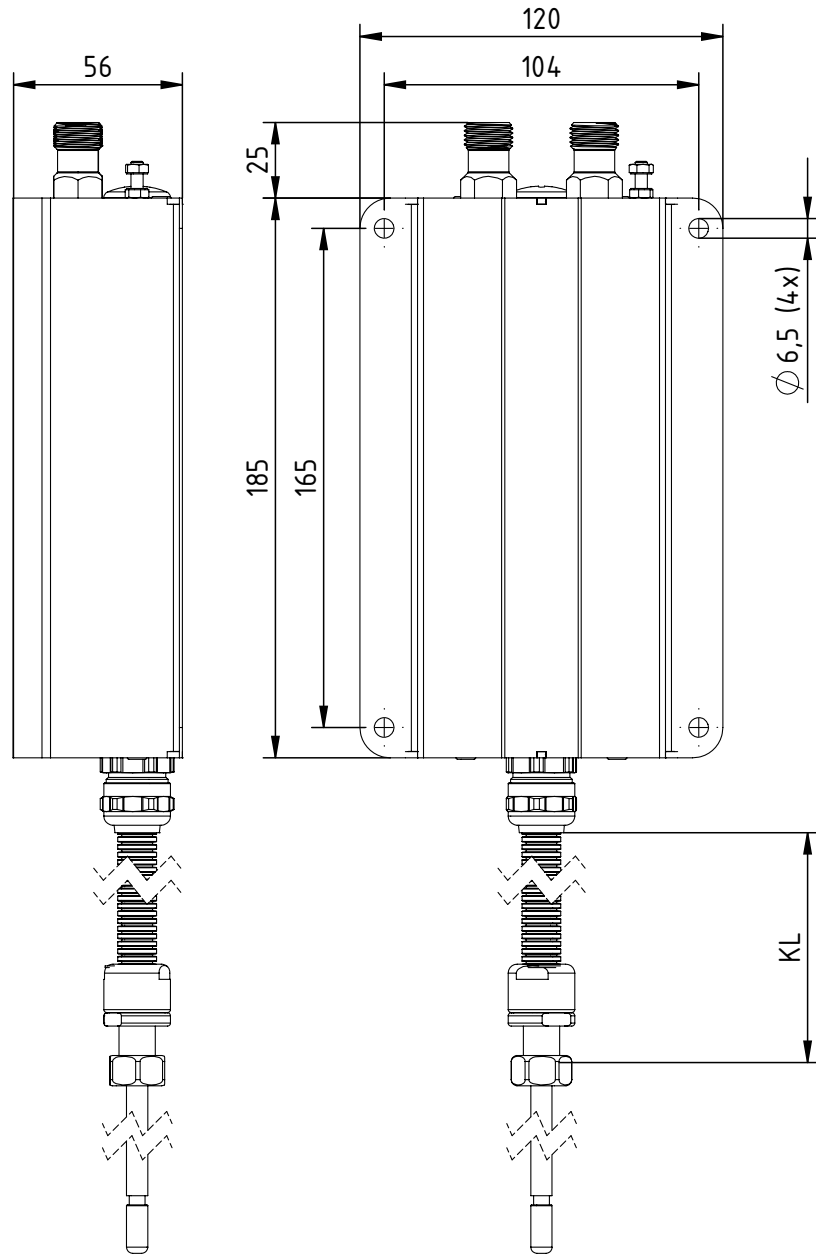

Fig. 56:
Dimensions
Distributor
PCV/Y

Z-117457ay_3

8.2.2 Distributor PCV6 (max. 60 kV)

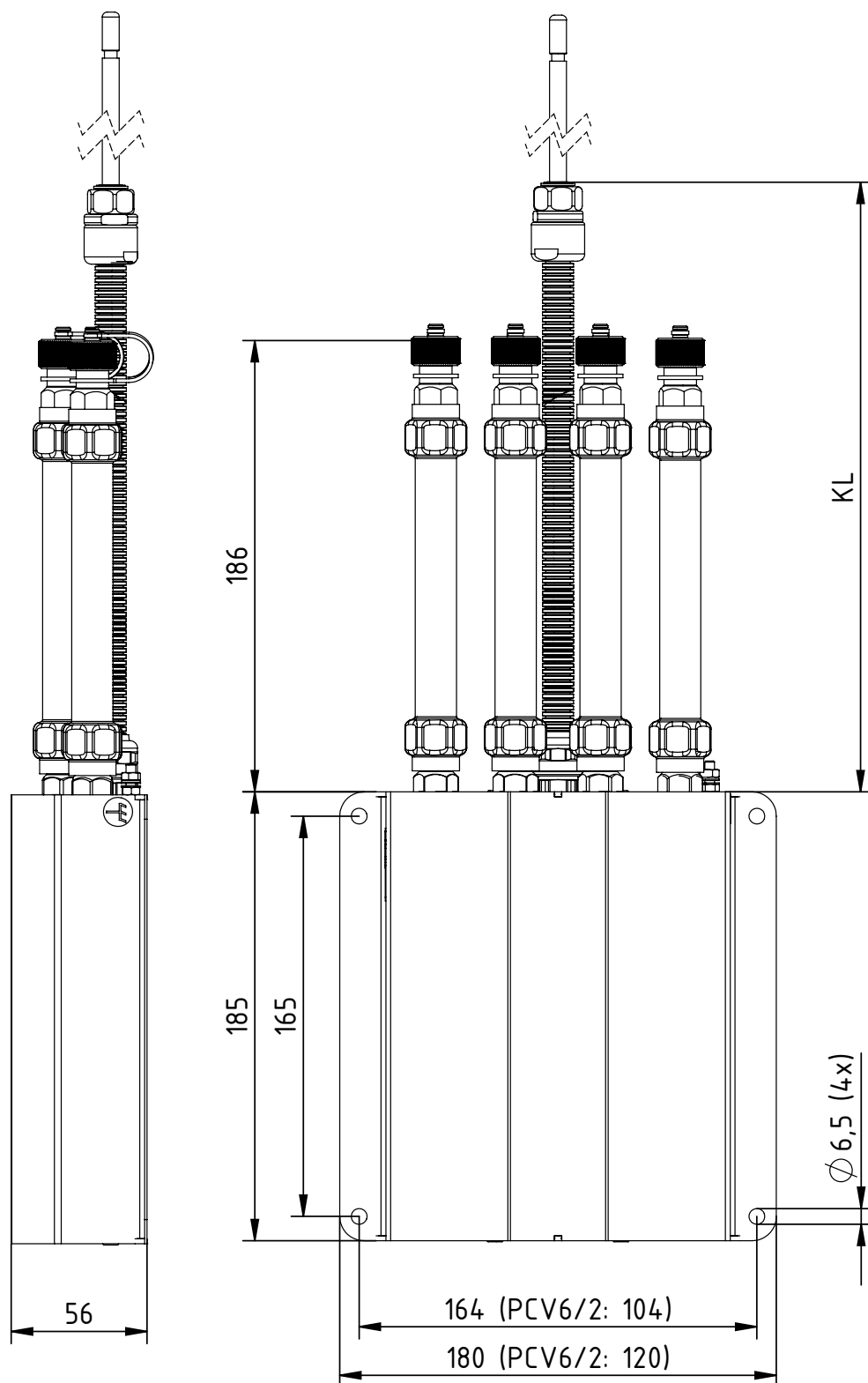

Fig. 57:
Dimensions
Distributor
PCV6/2, PCV6/4

Z-118054ay_2

8.3 Extension cable KA/YY_ _ _ (max. 30 kV)

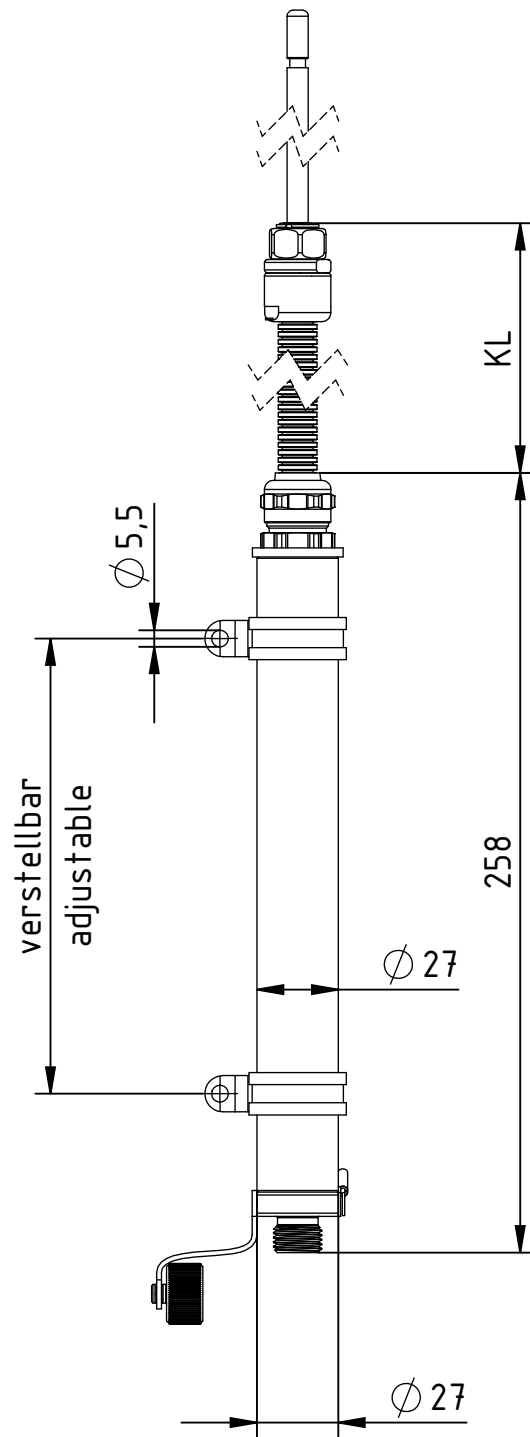

Fig. 58:
Dimensions
Extension cable
KA/YY_ _ _

Z-117693ay_1y

Article	Article No.
Protective cap M16 plug	ELM01115
Terminating plug male CANopen®	114855
Terminating plug female CANopen®	117550
Fine wire fuse AC version	ELM00201
Plug "Y" Set for prefabricating the high voltage cable with flexible tube for 30 kV charging bars resp. modification set for charging plug Y	117985
Plug "X" Set for prefabricating the high voltage cable with flexible tube for 60 kV charging bars resp. modification set for charging plug X	117986
Plug "L" Set for prefabricating the high voltage cable with flexible tube for 5 kV discharging bars	103289
High voltage cable with flexible tube from the generator PC__ / or distributor PCV/ __ to the charging bar (max. 30 kV), specify cable length Using charging bars for the Ex area, the coupling area (plug / socket) of this extension cable must be outside the Ex area.	KA/YY _ _ _
High voltage distributor 30 kV Specify number of connections and cable length	PCV/ _ _
High voltage distributor 60 kV Specify number of connections and cable length	PCV6/ _ _
Volt Stick	109136
Operating Instructions (specify language)	BA-xx-3041

Please specify the article number when ordering.

9. Spare parts and accessories

Article	Article No.
Mains cable 24 V DC (specify customer-side connection and cable length)	KN/H_ _ _ _ _
Mains cable Standard with plug for power cable, form C13, with integrated locking (specify customer-side connection and cable length)	KN/G_ _ _ _ _
Mains cable Standard (shockproof plug), cable length 2 m	116327
Mains cable USA, cable length 2 m	116328
Plug M16 for 24 V DC supply voltage, confectionable	116136
Plug for power cable for AC power supply, with locking bracket, confectionable	116329
Interface cable: I/O interface Charging, open cable ends on consumer side (specify cable length)	CS/AMO_ _ _ _
Plug M12, 8-pin for I/O interface Charging	116137
Interface cable: I/O interface Discharging open cable ends on consumer side (specify cable length)	CS/EMO_ _ _ _
Plug M12, 5-pin for I/O interface Discharging	116138
Interface cable Field bus CANopen®, male on customer side Plug / Socket, straight / angled or open cable ends selectable (specify cable length)	CS/CM_ _ _ _ _
Interface cable Field bus CANopen®, female on customer side Plug / Socket, straight / angled or open cable ends selectable (specify cable length)	CS/CF_ _ _ _ _
T-distributor M12, 5-pin, shielded	114854
Adapter D-Sub socket, M12 plug	114858
Interface cable Field bus industrial Ethernet, male on customer side Plug, straight / angled or open cable ends selectable (specify cable length)	CS/IM_ _ _ _ _
Interface cable Field bus industrial Ethernet, male on customer side RJ45 (specify cable length, max. 10 m)	CS/IMR_ _ _ _
Protective cap High voltage output, Charging	116032
Protective cap M12 plug	108448
Protective cap Service interface	116121
Protective cap M12 socket	108449

10. Decommissioning / Battery removal

Follow the instructions below to dispose of the generator:



Caution!

All work must be carried out by qualified electricians only.



Warning!

Electric shock hazard!

Before opening the generator, switch it off and disconnect all plug connectors and cables.

Please note that there is a risk of electric shock due to the energy that is stored in the electronic components. Wait a while before opening the generator and then make sure it is de-energized before you remove the battery.

Battery replacement is not permitted. There is a risk of explosion if the wrong type of battery is used!

The integrated battery of the generator must be removed and disposed of separately. To do so, open the plate at the rear of the housing, remove the lithium battery and dispose of it separately.

Once the battery has been removed, the generator can be disposed of as electronic scrap.

A. ANNEX

A.1 Assembly of the plugs

A.1.1 Plug M16 for 24 V DC supply voltage straight version, version with shield clamping ring

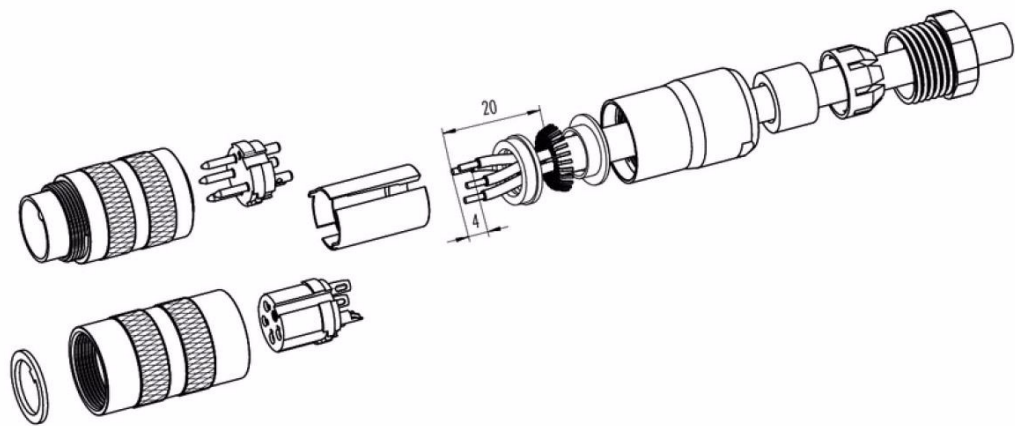

Fig. 59:
Plug
M16 for 24 V DC
supply voltage

1. Bead pressing screw, pinch ring, seal, distance shell and first shield clamping ring on cable.
2. Strip wires, widen shield and bead second shield clamping ring.
3. Solder wires, snap distance shell, push the two shield clamping rings together and cut off projecting shielding braid.
4. Assemble remaining parts according to figure.

Z-116136y

A.1.2 Plug for power cable for AC supply voltage

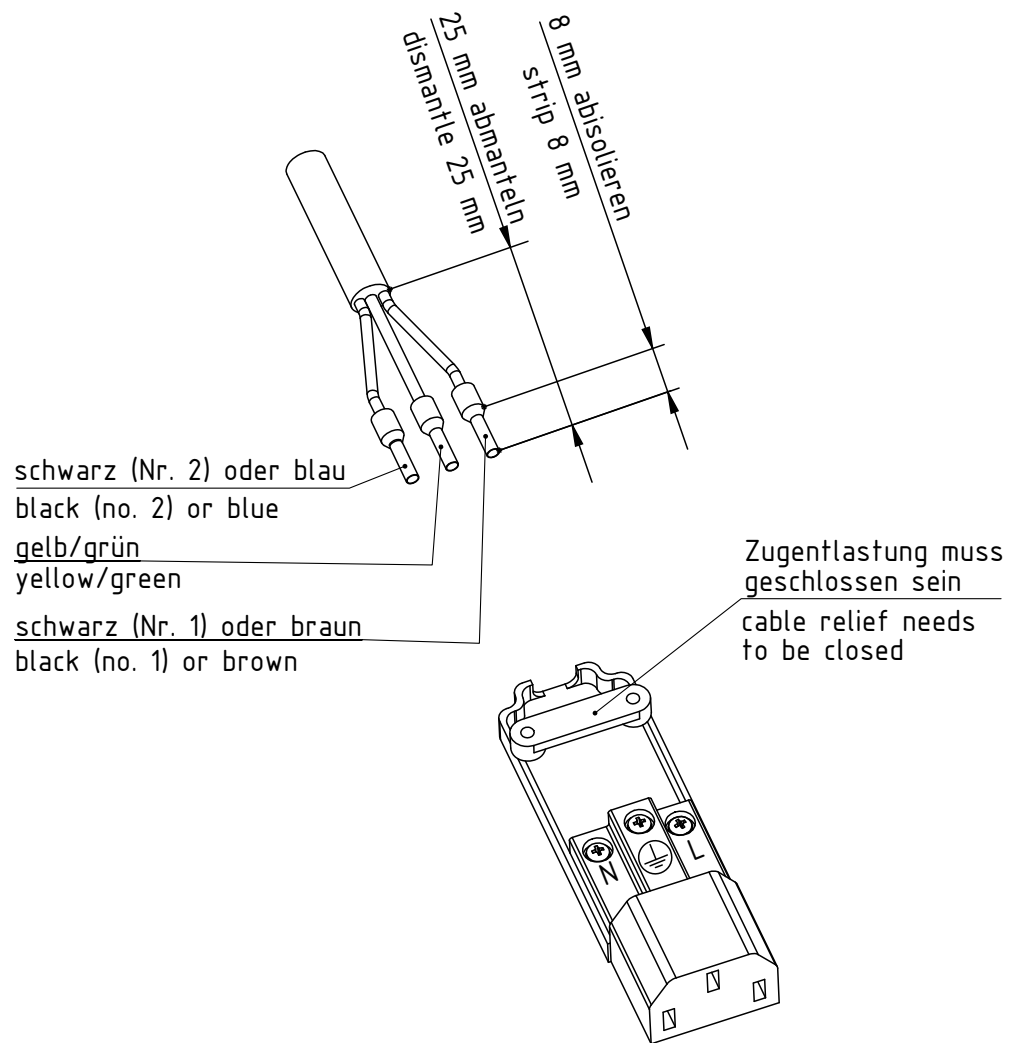

Fig. 60:
Plug
for power cable for
AC supply voltage

Z-116378ay

A.1.3 Plug M12, 8-pin for I/O interface Charge

A = 5 mm

Schirmdurchmesser >5,5 mm
shielding braid diameter >5,5 mm

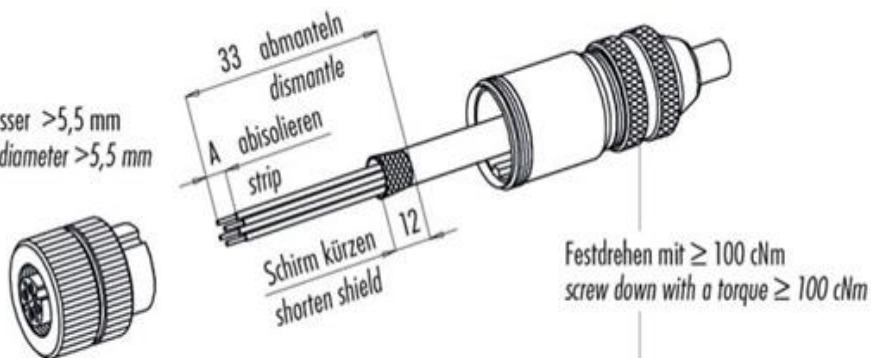

Schirmdurchmesser $\leq 5,5$ mm
shielding braid diameter $\leq 5,5$ mm

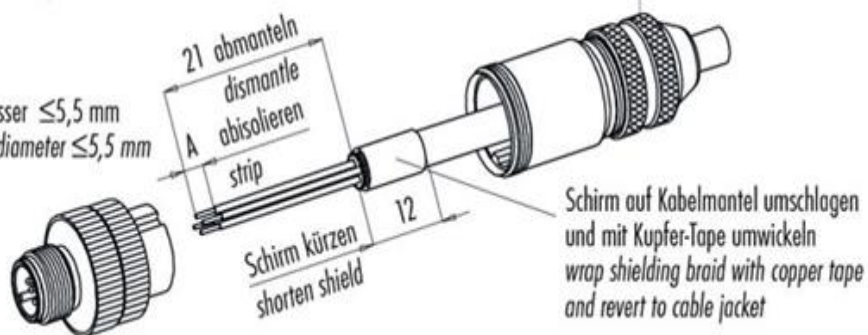
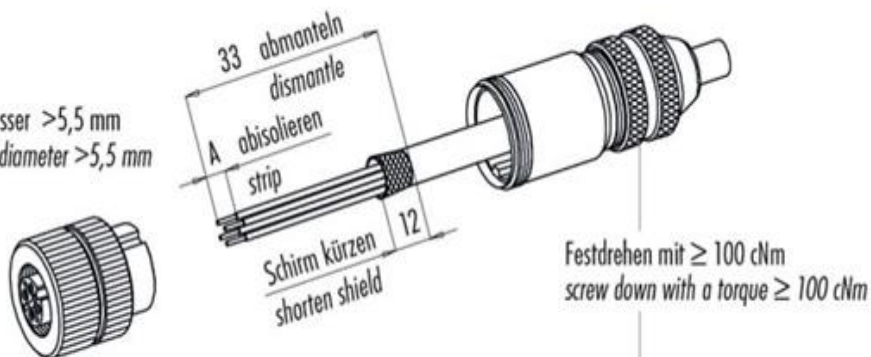

Fig. 61:
Plug M12, 8-pin
for I/O interface
Charge

A.1.4 Plug M12, 5-pin for I/O interface Discharge

A = 5 mm

Schirmdurchmesser >5,5 mm
shielding braid diameter >5,5 mm



Schirmdurchmesser $\leq 5,5$ mm
shielding braid diameter $\leq 5,5$ mm

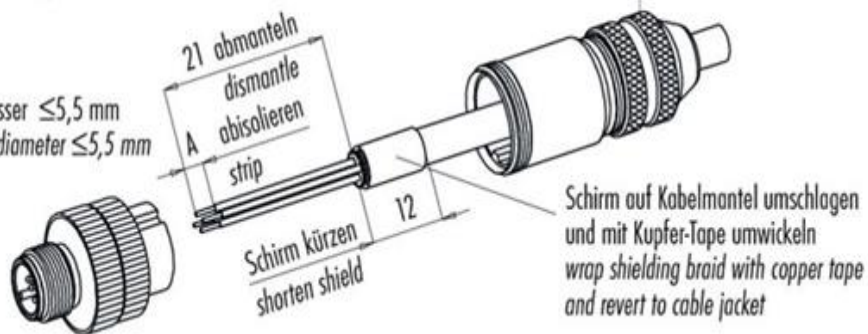

Fig. 62:
Plug M12, 5-pin
for I/O interface
Discharge

A.2 Pollution monitoring

Charging

The pollution monitoring is an additional function for monitoring the impression roller electrode; it is available in the generator variants with display and integrated fieldbus. For using this function, the parameter value for pollution monitoring must be set accordingly.

The current degree of the pollution is determined by comparing the parameterizable nominal resistance and the current load resistance of the charging. If this load resistance decreases, the electrode becomes conductive. In the case of insulating pollution, the value increases accordingly.

The calculation of the nominal resistance can be done by manually calculating the resistance value, reading out the current actual value for the load resistance of the charging or the automatic contamination calibration. It should be noted, however, that the calculation must be carried out with a new or freshly cleaned electrode.

The nominal resistance for the individual conditions must be determined separately. Particularly when using different substrates, it is necessary to determine the corresponding nominal resistance for reliable use of the pollution monitoring. With the automatic calibration of the pollution monitoring, the actual value of the load resistance is recorded and averaged over a period of 20 minutes.

The current level of pollution is a percentage value. If 0 % is displayed, the current value of the load resistance is equal to that of the nominal resistance. 100 % is a doubling or halving of the load resistance compared to the nominal resistance.

If the degree of pollution exceeds 80 %, the corresponding warning message is set. The error message for pollution occurs with a value greater than 100 %.

Discharging

A pollution monitoring of the discharge electrodes is not integrated. The detection of the pollution of the electrode is indirectly done via the actual values for the discharge current and voltage. If corresponding error messages occur for the discharge current and the discharge voltage, the electrode must be checked and cleaned accordingly.

A.3 Detection of flashes

Flashes are excursive changes in the actual value of the charging current. These can be caused by grounded substrates in the area of the charging bar, damaged high voltage cables, etc. A flash detection is integrated to ensure that the generator operates as trouble-free and as long as possible. The flash detection recognizes the flashes and generates error or warning messages if the set limit is exceeded. The detection takes place with activated charging.

The limits for the detection can be set to optimize the flash detection. Basically, two types of flashes can be identified: hard and soft flashes.

In both cases, the detection is the same. Only the sensitivity for detection is different. The flashing is recognized if the excursive current change in the detection period is greater than the percentage factor set for the type of flashing. The factor always refers to the maximum output current of the generator.

Example:

$I_{max} = 7,5 \text{ mA}$, factor = 10 %

Flash detection takes place at $> 0.75 \text{ mA}$

If the current change exceeds the level of the detection period, the corresponding counter is incremented. If the counter exceeds the set value of the counter limit, an error or warning message is generated. If there are no further flashes within ten seconds of detecting a flash, the individual counters are counted down step by step.

A.4 Overview of the actual values and parameters

A.4.1 Actual values: Charging

Function	Description	Standard access level
Voltage Charging	Voltage output of the high voltage Charging	User
Current Charging	Current output of the charge	User
Operating mode Charging	Current operating status of the charge with display of the mode and possibly active limiter	User
Power Charging	Power output of the charge	User
Voltage capacity Charging	High voltage capacity of the charge in percentage	User
Current capacity Charging	Current capacity of the charge in percentage	User
Power capacity Charging	Power capacity of the charge in percentage	User
Pollution Charging	Deviation in percentage of the current load resistance of the charge with the stored nominal resistance for pollution monitoring (see Chap. A.2)	User
Hard flashes Error counter	Error counter of the hard flashes detection (see Chap. A.3)	User
Hard flashes Warning counter	Warning counter of the hard flashes detection (see Chap. A.3)	User
Soft flashes Error counter	Error counter of the soft flashes detection (see Chap. A.3)	User
Soft flashes Warning counter	Warning counter of the soft flashes detection (see Chap. A.3)	User
Load resistance	Load resistance of the charging	User

A.4.2 Actual values: Discharging

Function	Description	Standard access level
Voltage Discharging	Effective value (RMS) of the sinusoidal output voltage of the high voltage, discharge	User
Active current Discharging	Effective value (RMS) of the active sinusoidal alternating current of the discharge	User
Passive current Discharging	Effective apparant power of the discharge	Super User
Power Discharging	Output power of the discharge	Super User
Operating mode Discharging	Current operating status of the discharge with display of the mode and possibly active limiter	User
Capacity Discharging	High voltage capacity of the discharge in percentage	User

A.4.3 Actual values: General

Function	Description	Standard access level
Supply voltage	Voltage of the internal supply voltage	Super User
Supply current	Current of the internal supply voltage	Super User
Supply power	Power input of the internal supply voltage	Super User
Supply capacity	Power capacity of the power supply in percentage	Super User

A.4.4 Charging Parameters

Function	Description	Standard access level	Range	Factory setting
Voltage setpoint Charging	Setting of the high voltage setpoint, Charging	Viewer (read) User (write)	$U_{\min} - U_{\max}$	U_{\min}
Current setpoint Charging	Setting of the current setpoint, Charging	Viewer (read) User (write)	$I_{\min} - I_{\max}$	I_{\max}
Operating mode Charging	Setting of the operating status, Charging	Viewer (read) User (write)	voltage constant, current constant	voltage constant
Setpoint Charging	Setting of the setpoint in percentage. The corresponding setpoint is changed depending on the operating status.	Super user (read) Super user (write)	0 - 100 %	5 %
Ramp time	Ramp-up time of the high voltage, Charging	Super user (read) Super user (write)	100 ms - 10,000 ms	500 ms
Hard flashes Factor	Setting of the sensitivity for the detection of hard flashes	Super user (read) Super user (write)	25 % - 40 %	25 %
Soft flashes Factor	Setting of the sensitivity for the detection of soft flashes	Super user (read) Super user (write)	10 % - 25 %	10 %
Limit Flash counter	Limit for the detection of errors or warnings of the respective flash counter	Super user (read) Super user (write)	0 - 1,000	10
Nominal resistance Charging	Determined standardized resistance of the charging for the detection of pollution	Super user (read) Super user (write)	0 k Ω - 1,000,000 k Ω	0 k Ω
Pollution monitoring	Pollution detection of the charging bars	Super user (read) Super user (write)	OFF ON calibration	OFF

A.4.5 Discharging Parameters

Function	Description	Standard access level	Range	Factory setting
Voltage Setpoint Discharge	Setting of the high voltage setpoint, Discharging	Viewer (read) User (write)	3,500 V - 5,000 V	5,000 V
Operating mode Discharge	Selection of the operating status, Discharging	Super user (read) Super user (write)	passive discharge, active discharge	active discharge
Ion balance	Discharge optimization of the balance setting of positive and negative ions	Viewer (read) User (write)	0 - 100 %	50 %
Setpoint Discharge	Setting of the high voltage setpoint in percentage, Discharging	Super user (read) Super user (write)	0 - 100 %	100 %
Frequency Discharge	Setting of the high voltage frequency, Discharging	Viewer (read) User (write)	50 Hz, 55.7 Hz, 62.5 Hz, 71.4 Hz, 83.3 Hz, 100 Hz, 125 Hz, 166.7 Hz 250 Hz	50 Hz

A.4.6 General Parameters

Function	Description	Standard access level	Standard access level	Range
High voltage release mode	Release mode of the high voltage	Super user (read) Super user (write)	automatically, analog setpoint, HMI, fieldbus	HMI
LED Bar Mode	Switching the view of the LED bar of the power supply	Super user (read) Super user (write)	voltage, current	voltage

A.4.7 Interface Parameters

Function	Description	Standard access level	Standard access level	Range
Analog setpoint	Selection of the I/O interface for setpoint setting, Charge	Super user (read) Super user (write)	OFF, current 0 -20 mA, voltage 0 - 10 V, limiter signal, current 0 -20 mA + limiter signal, voltage 0 - 10 V + limiter signal	Aus
CANopen® node address	Adjustment of the CANopen® node adresse for the	Super user (read) Super user (write)	1 - 127	99
CANopen® baud rate	Adjustment of the CANopen® baud rate for the device	Super user (read) Super user (write)	10 kBit/s, 25 kBit/s, 50 kBit/s, 125 kBit/s, 250 kBit/s, 500 kBit/s, 800 kBit/s, 1000 kBit/s	125 kBit/s

EU-Declaration of Conformity

CE-3041-en-2402



Eltex-Elektrostatik-Gesellschaft mbH
Blauenstraße 67 - 69
D-79576 Weil am Rhein



declares in its sole responsibility that the product

High voltage generator Type POWER CHARGER PC (according to Eltex reference code)

complies with the following directives and standards.

Relevant EU-Directive:

2014/35/EU

Low Voltage Directive

Harmonized standard applied:

EN 60204-1:2018

Safety of machinery – Electrical equipment of machines –
General requirements

Relevant EU-Directive:

2014/30/EU

EMC Directive

Harmonized standards applied:

EN 55011:2016 + A1:2017
+ A11:2020 + A2:2021

Industrial, scientific and medical equipment –
Radio-frequency disturbance characteristics – Limits and methods
of measurement

EN IEC 61000-3-2:2019
+ A1:2021

Electromagnetic compatibility (EMC) – Limits – Limits for harmonic
current emissions (equipment input current ≤ 16 A per phase)

EN 61000-3-3:2013 + A1:2019
+ A2:2021 + A2:2021/AC:2022

Electromagnetic compatibility (EMC) – Limits – Limitation of voltage
changes, voltage fluctuations and flicker in public low-voltage supply
systems, for equipment with rated current ≤ 16 A per phase and not
subject to conditional connection

EN IEC 61000-6-2:2019

Electromagnetic compatibility (EMC) – Generic standards –
Immunity for industrial environments

EN 61000-6-7:2015 + A11:2024

Electromagnetic compatibility (EMC) – Generic standards –
Immunity requirements for equipment intended to perform functions in
a safety-related system (functional safety) in industrial locations

Relevant EU-Directive:

2011/65/EU

RoHS Directive

Harmonized standard applied:

EN IEC 63000:2018

Technical documentation for the assessment of electrical and
electronic products with respect to the restriction of hazardous
substances

in the version effective at the time of delivery.

Eltex-Elektrostatik-Gesellschaft mbH keep the following documents for inspection:

- proper operating instructions
- plans
- other technical documentation

Weil am Rhein, 15.02.2024
Place/Date

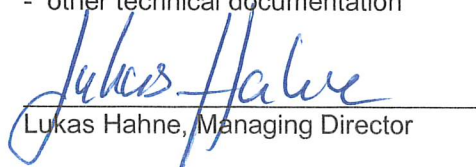
Lukas Hahne, Managing Director

UKCA Declaration of Conformity

CA-3041-en-2402

Eltex-Elektrostatik-Gesellschaft mbH
Blauenstraße 67 - 69
D-79576 Weil am Rhein



declares in its sole responsibility that the product

High voltage generator Type POWER CHARGER PC (according to Eltex reference code)

complies with the following directives and standards.

Applicable Regulation:

S.I. 2016 No. 1101

Electrical Equipment (Safety) Regulations

Used Designated Standard:

BS EN 60204-1:2018

Applicable Regulation:

S.I. 2016 No. 1091

Electromagnetic Compatibility Regulations

Used Designated Standard:

BS EN IEC 61000-3-2:2019+A1:2021

BS EN 61000-3-3:2013+A2:2021

BS EN IEC 61000-6-2:2019

BS EN 61000-6-7:2015+A11:2024

BS EN 55011:2016+A2:2021

Applicable Regulation:

S.I. 2012 No. 3032

RoHS Regulations

in the version effective at the time of delivery.

Eltex-Elektrostatik-Gesellschaft mbH keep the following documents for inspection:

- proper operating instructions
- plans
- other technical documentation

Weil am Rhein, 15.02.2024
Place/Date



Lukas Hahne, Managing Director

Eltex offices and agencies

The addresses of all
Eltex agencies can be
found on our website at
www.eltex.de



z01007y



Eltex-Elektrostatik-Gesellschaft mbH
Blauenstraße 67-69
79576 Weil am Rhein | Germany
Phone +49 (0) 7621 7905-422
eMail info@eltex.de
Internet www.eltex.de