

Operating Instructions

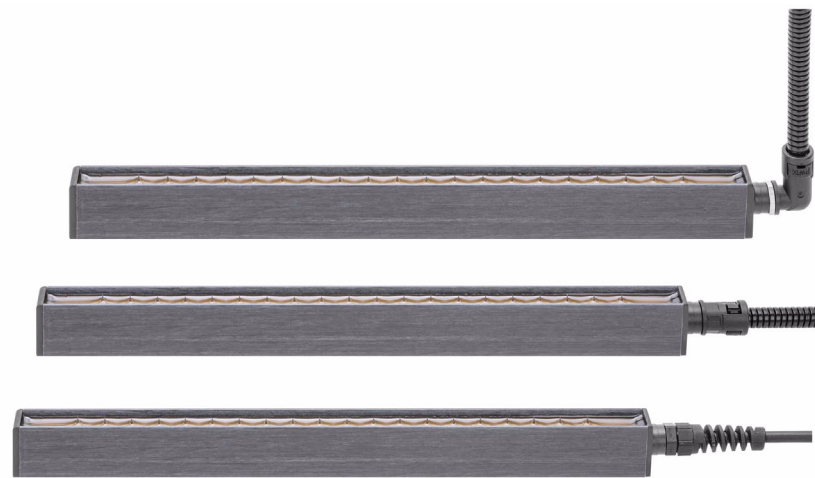

F01091y

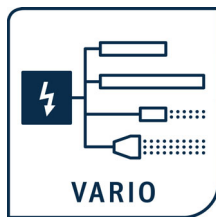

blueBAR discharging bar

Serie R50 / R51A for AC Operation

BA-en-2016-2503



List of contents

1	Outline of appliance	6
2	Safety	8
2.1	Proper use	8
2.2	Identification of risks and hazards	8
2.3	Work and operational safety	9
2.4	Contact protection	11
2.5	Inspection of the protective resistors - contact protection	11
2.6	Technical advance	11
3	Installation and assembly	12
3.1	Assembling the discharging bar	12
3.2	Adjust the angle coupling	16
3.3	Length of the high voltage cable	17
3.4	Connecting the high voltage cable	17
3.5	Connecting the high voltage cable to the R51A discharging bar	18
4	Operation	21
4.1	Startup	21
4.2	Function control	21
5	Maintenance	22
6	Trouble-shooting	23
7	Technical specifications	24
8	Dimensions	27
9	Spare parts and accessories	28
	Declaration of Conformity	30
	UKCA Conformity	31

Dear customer,

The new Series R50 and R51A discharging bars are designed for the active discharging of disruptive static charges which develop in production processes. The bars are operated with an alternating voltage of max. 8 kV at 50...250 Hz and are designed for discharging moving surfaces.

Due to differences in the surface charge profiles on different materials, charges with both polarities are provided by the discharging bars. The corona section with its optimized geometrical configuration ensures ultimate discharging efficiency.

The advantages of the R50 / R51A discharging bars:

- ultimate discharging range and hence enhanced depth effect
- high active discharging power through patented, isolated ground conductors
- high safety standards through passive discharging power with deactivated power supplies
- safety through function and malfunction monitoring
- continuous assembly slotting guarantees flexible installation
- no health hazards in case of electric shocks when touching individual tips (≤ 10 tips)

The optimum discharging effect is guaranteed in conjunction with the Eltex high voltage power supplies.

Please read the operating instructions carefully before operating the unit. This will help you prevent personal injuries and damage to property.

Please give us a call if you have any suggestions, proposals or ideas for improvements. We greatly appreciate the feedback from the users of our appliances.

1. Outline of appliance

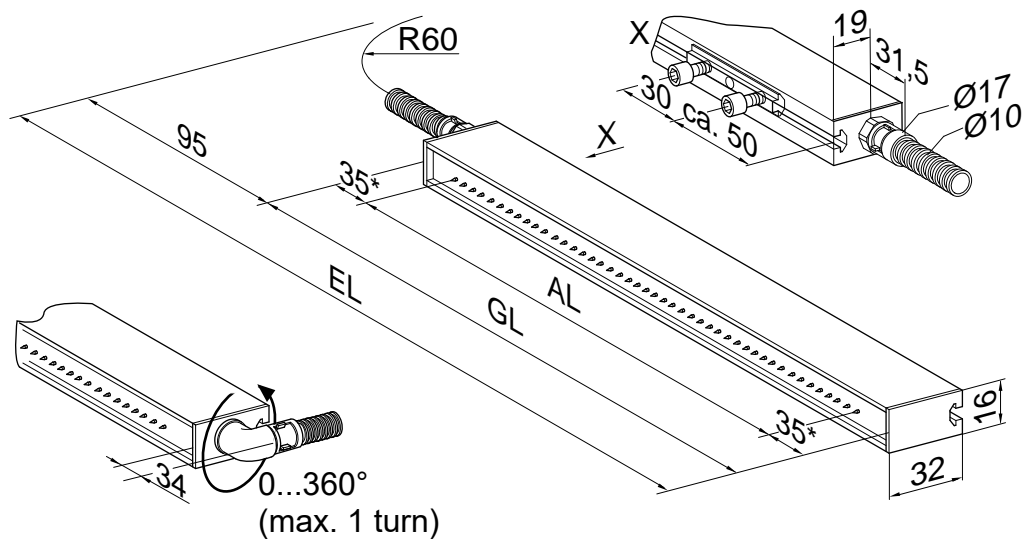

Z00062y

Fig. 1:
Overview of the
R50 / R51A
discharging bar

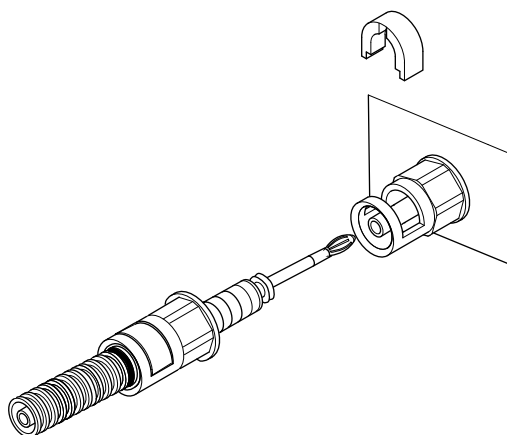

Z00004y

* for R51A: 40 mm

EL = installation length

AL = active length

GL = total length

Design variants

R50 discharging bar

- fixed connection of the high voltage cable
- high voltage cable leads out from the bar in axial or radial direction
- radial connection rotatable by 360° and locked in the desired position by means of a lock nut
- maximum active length = 5910 mm
- grid width 15 mm
- For the serial interconnection of several R50 bars, the variants R50/D (axial high voltage cable lead-out) and R50/E (radial high voltage cable lead out) with an additional axial connection are available.

R51A discharging bar

- detachable connection of the high voltage cable
- high voltage cable leads out from the bar in axial direction
- maximum active length = 5910 mm
- grid width 15 mm
- design variant with two axial connections for serial interconnection of several R51A discharging bars
- not approved for connection to the ES24, ES60, ES61, PI power supply units

2. Safety

The units have been designed, built and tested using state-of-the-art engineering, and have left the factory in a technically and operationally safe condition. If used improperly, the units may nevertheless be hazardous to personnel and may cause injury or damage. Read the operating instructions carefully and observe the safety instructions.

For warranty conditions, please refer to the General Terms and Conditions (GTC), see www.eltex.de.

2.1 Proper Use

The Series R50 / R51A discharging bars must be used only for discharging static charges from material surfaces. Other uses are not permitted.

The discharging bars must be operated only together with the dedicated Eltex power supplies. These power supplies guarantee the optimum adaptation to the required operational data for the different active bar lengths. Safe operation of the bars is ensured only by using the Eltex power supplies.

Other uses are not permitted. The manufacturers will not assume any liability and warranty if the units are used improperly or used outside the intended purpose.

Modifications or changes made to the devices are not permitted.

Use only original Eltex spare parts and equipment.

2.2 Identification of risks and hazards

Possible risks and hazards resulting from the use of the units are referred to in these operating instructions by the following symbols:



Warning!

This symbol appearing in the operating instructions refers to operations which, if carried out improperly, may result in serious personal injuries.



Caution!

This symbol appearing in the operating instructions refers to operations which, if carried out improperly, may result in damage to property.

2.3 Work and operational safety



Warning!

Carefully observe the following notes and the complete [chapter 2 "Safety", page 8!](#)

- Before carrying out repairs, cleaning or maintenance work and before resetting after malfunctions, switch off the power supply and disconnect the mains supply voltage (see [chapter 5 "Maintenance", page 22](#), [chapter 6 "Trouble-shooting", page 23](#)).
- Before carrying out any work involving the units, the machine which has the units fitted must not be in operation (see [chapter 5 "Maintenance", page 22](#), [chapter 6 "Trouble-shooting", page 23](#)).
- Any work involving the units must be carried out by qualified electricians (see [chapter 5 "Maintenance", page 22](#), [chapter 6 "Trouble-shooting", page 23](#)).
- The bars passively absorb energy from the moving substrate web. The high voltage cable must be plugged in or grounded to the power supply. If the high voltage cable is disconnected, the plug is live (high voltage) and applies with full power on the plug; this may cause a spark discharge and may lead to a risk of injury. Disconnected high voltage plugs are not permitted or have to be grounded (see [chapter 5 "Maintenance", page 22](#)).
- When connecting the high voltage cables to the power supply unit resp. the high voltage distributors, the machine which has the discharging bars fitted must be switched off and also the supply voltage to the power supply must be disconnected (see [chapter 3.5 "Connecting the high voltage cable to the R51A discharging bar", page 18](#), [chapter 5 "Maintenance", page 22](#), [chapter 6 "Trouble-shooting", page 23](#)).
- The bar must be mounted such that mechanical damage to the bar tips is ruled out (see [chapter 3.1 "Assembling the discharging bar", page 12](#)).
- To attach the cables, use only sliding nuts and bolts made of plastic (see [chapter 3.1 "Assembling the discharging bar", page 12](#)).
- When routing the cable, select the attachment points such that mechanical damage to the cable (e.g. chafing against rotating machine parts) is ruled out (see [chapter 3.1 "Assembling the discharging bar", page 12](#)).
- In applications involving moving bars, the high voltage cable must be attached such that there is no cable movement near the connection zone of the power supply unit (see [chapter 3.1 "Assembling the discharging bar", page 12](#)).
- Switch off the bar when working with metal film or metal composites (see [chapter 3.1 "Assembling the discharging bar", page 12](#)).

- In bilateral discharging, the bars must not be mounted in opposition to each other (see [chapter 3.1 "Assembling the discharging bar", page 12](#)).
- The distance of the emission points to the conductive, earthed printing press area should be greater than to the substrate to be discharged (see [chapter 3.1 "Assembling the discharging bar", page 12](#)).
- Both the lengths of the high voltage cable and of the active bars are limited, observe maximum lengths (see [chapter 3.3 "Length of the high voltage cable", page 17](#)).
- The maximum permissible angle of turn of the angle coupling is 360° (see [chapter 3.4 "Connecting the high voltage cable", page 17](#)).
- The shielded high voltage cable of the R51A discharging bar is detachable at the bar. Connect or disconnect the high voltage cable only with the power supply switched off (see [chapter 3.5 "Connecting the high voltage cable to the R51A discharging bar", page 18](#)).
- The discharging bars must be operated only in connection with the Eltex power supplies with max. 8 kV AC output (see [chapter 4 "Operation", page 21](#)).
- Check the units and the high voltage cables at regular intervals and before startup for any damage. Any damaged components must be repaired professionally or replaced before continuing to operate the unit, or the units must be disabled.
- Make sure that the units are clean at all times.
Dirt results in malfunctions and in premature wear of the units.
- When cleaning the bars do not soak the bars and the high voltage cable in solvent and do not damage the emission tips; allow the solvent to evaporate completely before restarting the unit (see [chapter 5 "Maintenance", page 22](#), [chapter 6 "Trouble-shooting", page 23](#)).
- Do not touch the emission tips - risk of injury.
Reflex responses to electrical irritation may increase the risk of secondary accidents, especially in the vicinity of unguarded rotating assemblies. The charging bar as such is safe to touch. If contact is made (single touch, ≤ 10 tips), the energy transferred is so low that there is no risk of injury.
- Potential risk for wearers of cardiac pacemakers:
Moving the chest closer than 3.5 cm to the emission tips of the discharging bars or making surface contact with several emission tips (touching a single tip is not critical) can result in a temporary switchover of the cardiac pacemaker into the fault mode. Permanent proximity or contact can therefore cause severe problems.
If it is likely that the chest of such a person comes closer than 3.5 cm to the emission tips of the discharging bar, or if several emission tips are touched at the same time, the appropriate warning notices must be displayed.

- Mechanical or electrical modifications of the discharging bars are not permitted. Shortening the shielded high voltage cable on the connecting side of the power supply is permitted. Extending the cable is permitted only when using the Eltex distributor as well as original high voltage cables and glands.
- During operation of the devices, small amounts of ozone (O₃) may be produced at the emission tips depending on a variety of boundary conditions such as site of installation, bar voltage and current, air circulation, etc.
If the maximum allowable concentration of ozone must be observed at the site of installation of the bar, the concentration must be measured on site.

2.4 Contact protection

The site of installation and/or use of the units is outside the control of Eltex, contact protection against inadvertent contact of the bars and of live components by personnel as specified by the employer's liability insurance association may have to be provided (e.g. DGUV V3 in Germany). Contact protection devices made of conductive material must be grounded.

2.5 Inspection of the protective resistors - contact protection

The function and the appearance of the protective resistors must be inspected at regular intervals. The inspection intervals are specified in the accident prevention regulations, as amended (e.g. in Germany DGUV V3).

The function of the series resistors must be checked using a suitable measuring device. The test voltage must be 1,000V. The measured resistance between the high-voltage connection and the individual emission tip must not fall below 120 MOhm and not exceed 180 MOhm.

2.6 Technical advance

The manufacturer reserves the right to make changes to the technical specifications without prior notice in order to adapt the units to state-of-the-art engineering. Eltex will provide the latest information on any changes or modifications in the operating instructions on request.

3. Installation and assembly

3.1 Assembling the discharging bar

Attach the Series R50 / R51A discharging bars to the machine wall, using flame-retardant GRP assembly material. For easier installation we recommend using the assembly material offered by Eltex. Fig. 2 shows the installation principle.

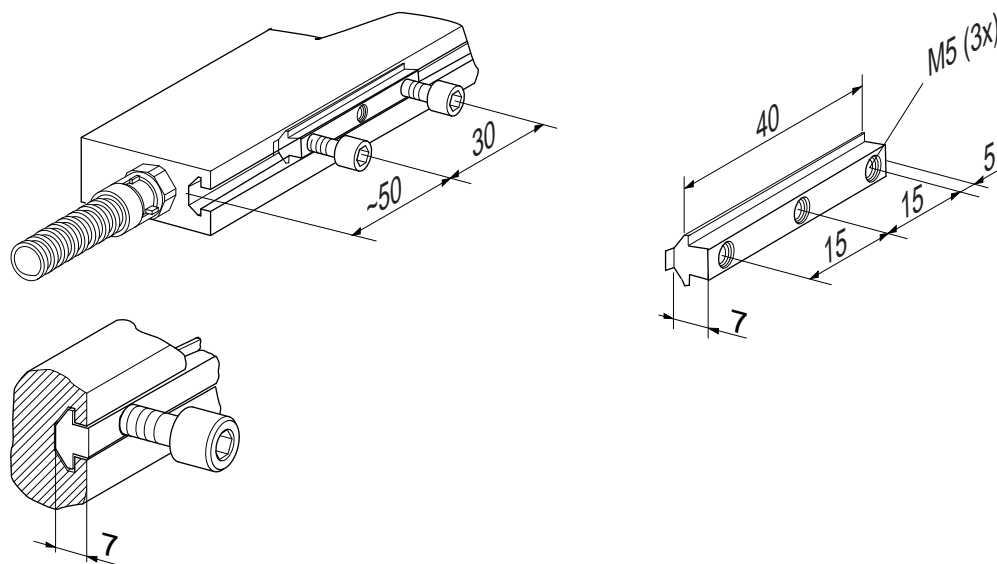

Fig. 2:
Assembling the
discharging bar

The profiled assembly section of the discharging bar is grooved. The sliding nuts pushed into this groove serve as bolt attachments for the GRP material, allowing the discharging bars to be installed.

Max. bolt depth 6.5 mm

Torque 0.4 Nm

Secure bolts (e.g. Loctite 243)



Caution!

Use only sliding nuts and bolts made of plastic!

below 1 meter total length: 2 per bar

below 2 meters total length: 3 per bar

below 3 meters total length: 4 per bar

below 4 meters total length: 5 per bar

below 5 meters total length: 6 per bar

below 6 meters total length: 7 per bar

An optional alternative is attaching the bars using a GRP round rod.

Fig. 4 shows an assembly example. The bar is attached to the GRP round rod via plastic holders plugged into the installation groove. Longer bars require an additional angle bracket bolted to the GRP rod to prevent the bar from sagging.

Plastic holders

below 1 meter total length: 3 per bar
 below 2 meters total length: 5 per bar
 below 3 meters total length: 7 per bar
 below 4 meters total length: 9 per bar
 below 5 meters total length: 11 per bar
 below 6 meters total length: 13 per bar

*Fig. 3:
 Assembly example
 R50 with GRP rod
 and steel brackets
 for attachment to
 the machine wall*

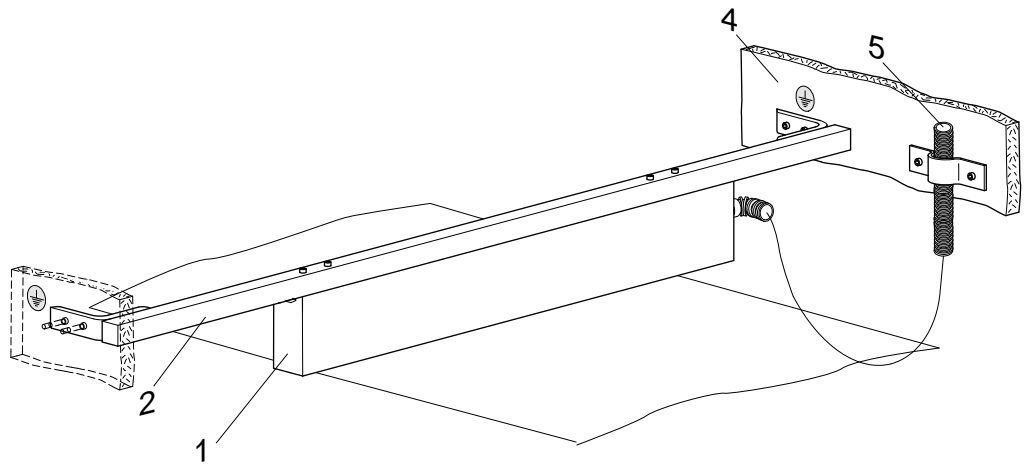

Z00121Y

*Fig. 4:
 Assembly R50
 with GRP round
 rod*

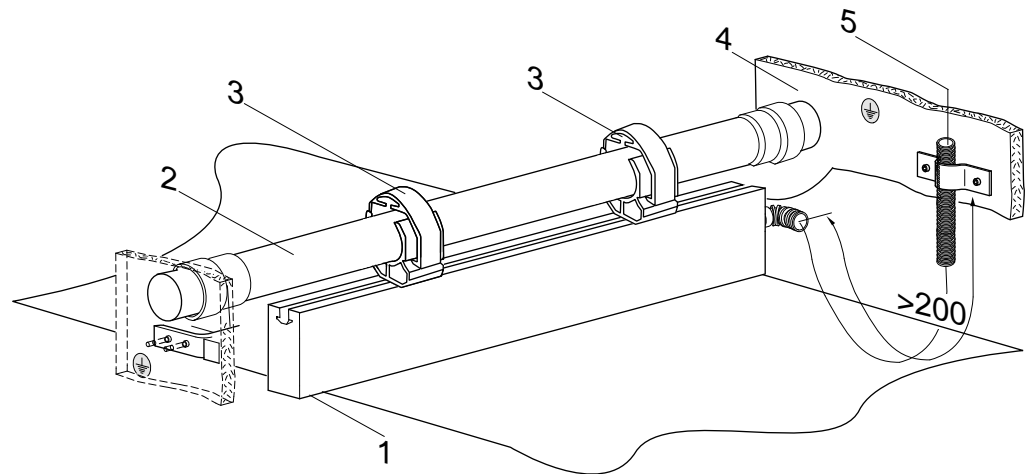

Z0034y

- 1 bar
- 2 GRP rod
- 3 plastic holder
- 4 machine wall
- 5 high voltage cable with flexible tube



Warning !

For safety in operation, please note the following:

- The bar must be mounted such that mechanical damage to the bar tips is ruled out.
- When routing the cable, select the attachment points such that mechanical damage to the cable (e.g. chafing against rotating machine parts) is ruled out.
- To attach the cables, use only sliding nuts and bolts made of plastic.
- In applications involving moving bars, the high voltage cable must be attached such that there is no cable movement near the connection zone of the power supply unit.
- Switch off the bar when working with metal film or metal composites!

Locating the discharging bar

The best possible discharging results are achieved if the bar is located in areas with minimum web capacities. In practical terms this means placing the bar with maximum distances from the machine environment, i.e. no discharging against the idler roller.

A rough guideline:



A space with the radius R of the bar distance to the web ought to be kept free of any conductive material (Fig. 5). The distance of the emission points to the conductive, earthed printing press area should be greater than to the substrate to be discharged.

Depending on application, the distance between discharging bar and substrate ought to be 30...100 mm.

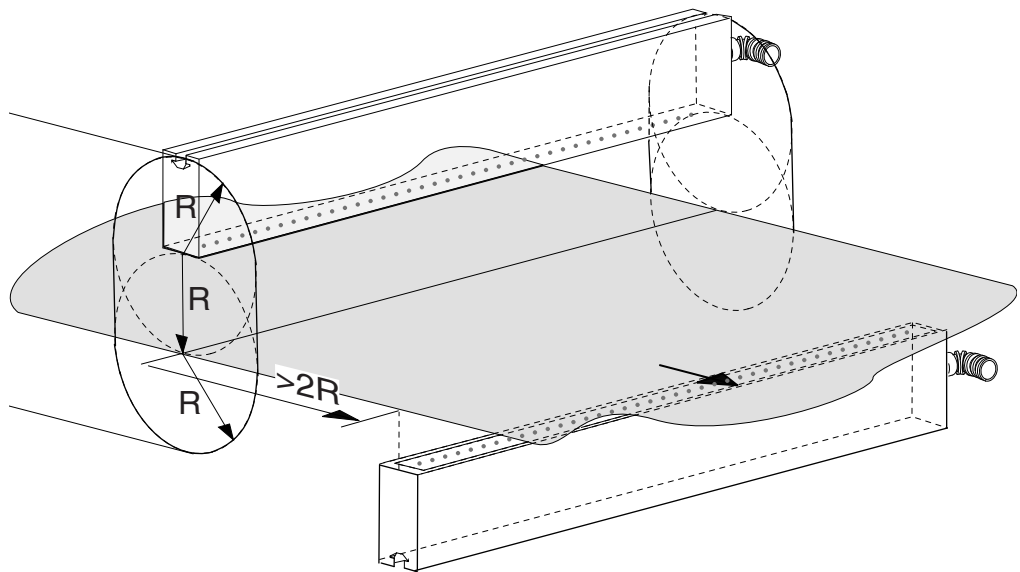

Fig. 5:
Zone free of conductive material with the dimensions R



In bilateral discharging, the bars must not be mounted in opposition to each other. The distance between both bars should be greater than twice the bar distance from the web.

Z00076y

3.2 Adjust the angle coupling

If the bar has a angle coupling, then it is aligned towards the tips during ex factory delivery.

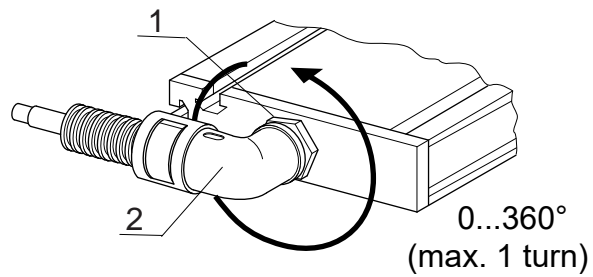

Fig. 6:
Angle coupling

- 1 lock nut
- 2 angle coupling

To turn the angle connection, proceed as follows:

- loosen the lock nut
- align the angle coupling in its desired position
- re-tighten the lock nut



The maximum permissible angle of turn of the angle coupling is 360°.

Z00065y

3.3 Length of the high voltage cable



The total length of discharging bar and high voltage cable is limited due to the loading capacity of the transformer in the power supply. The maximum loading capacity is a function of the active bar length and the length of the high voltage cables.

For connection to the power supply units of the ES5x, ES6x, ES24, PI series and the PC generators, see the separate operating instructions for the device used.

3.4 Connecting the high voltage cable

The connection of the high voltage cable of the discharging bars to the power supplies is described in the operating instructions of the respective power supplies.



Warning!

Electric shock hazard!

Work may be carried out only if:

- the supply voltage to the power supply / generator has been disconnected,
- the machine is at standstill because the bars pick up charges if the substrat web is running.

3.5 Connecting the high voltage cable to the R51A discharging bar

The shielded high voltage cable of the R51A discharging bar is detachable at the bar.



Warning!

Connect or disconnect the high voltage cable only with the power supply switched off.

Connection:

Note!

The cable must be clean. If necessary, clean the cable before connecting with benzine. Allow the solvent to dry off before connecting.

- Remove the blanking plug from the screw connection.
- Insert the high voltage cable together with the flexible tube as far as possible into the connection socket and secure the adapter with the clip.

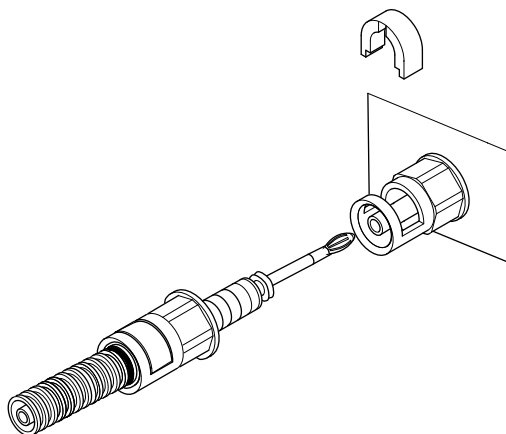

*Fig. 7:
Connecting the
high voltage cable
to the R51A dis-
charging bar*

Z000004y

Assembly:

If the plug connection has not been prefabricated for connection, prepare the high voltage cable as follows. This will ensure proper ground contact and hence the proper function of the discharging bar without the risk of electric shocks.

- Strip the high voltage cable as shown in Fig. 8.

Fig. 8:
Stripping the high voltage cable

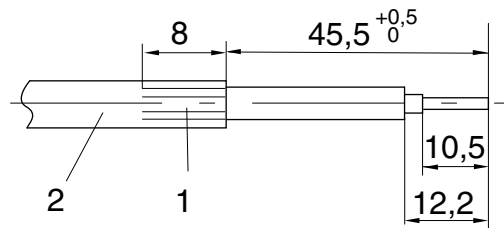

- 1 shielded braid turned back
- 2 high voltage cable

- Push the multidisc plug (4) over the stripped core (3) as shown in Fig. 9 and solder the plug at the tip (8). The projecting length of wire must be cut off.

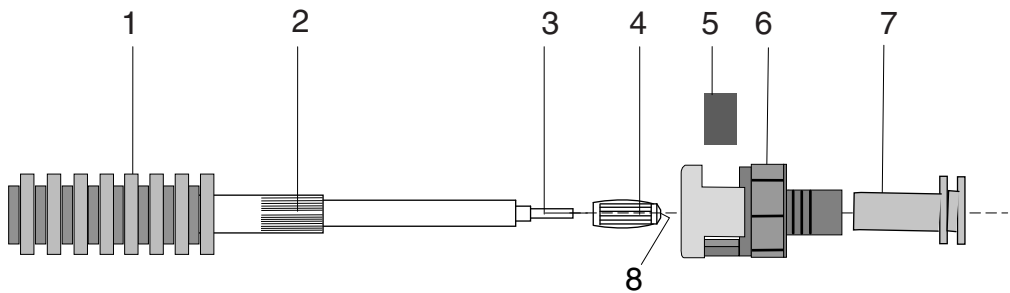
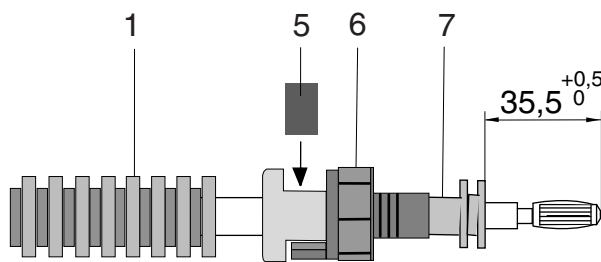

Fig. 9:
Prefabricating the high voltage cable



- Push the adapter (6) over the cable and the flexible tubing (1) and fix it in place with the clip (5).
- The flexible tubing must be pulled back for the next steps.
- Push the contact sleeve (7) over the folded back braiding (2) and crimp the sleeve using a hexagonal crimper (5.41 mm).
- The collar of the contact sleeve (7) must lie flush with the adapter (6).
- Now connect the cable as described in the above instructions.

The shielded high voltage cable of the R50 discharging bar is encapsulated in the bar and therefore not replaceable/ detachable.

For the connection to power supplies, refer to the separate operating instructions for the power supply.

Disassembly:

Remove the safety clip in the cable gland using a screwdriver. Pull off the high voltage cable. To protect from dirt, close the screw connection with the blanking plug.



4. Operation

The discharging bars must be operated only in connection with the Eltex power supplies with max. 8 kV AC output.

These power supplies guarantee the optimum adaptation to the specified operating conditions.

4.1 Startup

Once all the connections have been correctly made, the system is operational and the supply voltage can be switched on at the power supply.

4.2 Function control

Use the Eltex Volt Stick or a glow-lamp voltage tester to check the proper function of the emission tips. Quote Article No. 109136 when ordering the Volt Stick from Eltex.

5. Maintenance



Warning!

Electric shock hazard!

- Do not carry out any maintenance or repair work without first switching off the power supply and disconnecting the supply voltage.
- The machine which has the units fitted must not be in operation.
- The bars passively absorb energy from the moving substrate web. The high voltage cable must be plugged in or grounded to the power supply. If the high voltage cable is disconnected, the plug is live (high voltage) and applies with full power on the plug; this may cause a spark discharge and may lead to a risk of injury. Disconnected high voltage plugs are not permitted or have to be grounded.
- Repairs and maintenance work must be carried out by qualified electricians only.

To ensure the trouble-free function of the discharging bars, clean the bars regularly depending on pollution with compressed air free of oil and water (max. 6×10^5 Pa and standard compressed air pistol) and a brush with soft plastic bristles (see [chapter 9 "Spare parts and accessories"](#), [page 28](#)).

Clean grease, ink, glue, paper dust, etc. off the discharging bar using a suitable solvent (benzine). Do not soak the bars and the high voltage cable in solvent!



Caution!

Do not damage the emission tips when cleaning. Brush only in longitudinal direction.



Warning!

Risk of deflagration!

Allow the solvent to evaporate completely before restarting the unit.

Inspection of the protective resistors - contact protection

The function and the appearance of the protective resistors must be inspected at regular intervals. The inspection intervals are specified in the accident prevention regulations, as amended (e.g. in Germany DGUV V3).

The function of the series resistors must be checked using a suitable measuring device. The test voltage must be 1,000V. The measured resistance between the high-voltage connection and the individual emission tip must not fall below 120 MOhm and not exceed 180 MOhm.

6. Trouble-shooting



Warning!

Electric shock hazard!

- Do not carry out any maintenance or repair work without first switching off the power supply and disconnecting the supply voltage.
- The machine which has the units fitted must not be in operation.
- Repairs and maintenance work must be carried out by qualified electricians only.

Malfunction:

Effectiveness of the application declining.

Cause:

Dirty discharging bars.

Measure:

Clean bar with compressed air and a brush. Clean grease, ink, oil, etc. off the bar with a suitable solvent (benzine).

For further malfunctions, refer to the operating instructions for the power supplies.



Caution!

Do not leave the discharging bar to soak in the solvent!



Warning!

Risk of deflagration!

Allow the solvent to evaporate completely before restarting the unit.

7. Technical specifications

Discharging bar R50 / R51A	
Bar element	glass-fibre-reinforced plastic GRP
Encapsulation material	polyurethane, UL-94 V-0
Emission tips	stainless steel
Installation material	plastic sliding nuts
Operating ambient temperature	0...+80 °C (+32...+176 °F)
Ambient humidity	max. 70 % RH, non-dewing
Dimensions	profile: 16 x 32 mm, max. length R50: 5,980 mm; R51A: 5,990 mm, see Fig. 12
Weight	approx. 0.75 kg/m
Operating voltage	R50: max. 8 kV AC, 50 - 250 Hz R51A: max. 5 kV AC, 50 - 250 Hz
High voltage supply	via Eltex power supplies
High voltage connection	R50: high voltage cable encapsulated, axial or radial (rotatable by 360°) lead-out, optional: with additional connection for serial interconnection of several bars R51A: exchangeable high voltage cable, axial lead-out, optional: 2 connections for serial interconnection of several bars
Short-circuit current/tip	max. 0.046 mA
Contact protection	according to EN 61140
UL Approval	File No. E227156 (max. 6 kV AC, 50/60 Hz)

as shown on
appliance
marking:



Discharge times and ion balance

Discharge times (t_{90}) of a R50 bar with 105 mm active length in combination with the ES61 power supply.

Selected parameters:

voltage 4.4 kV, frequency 50 Hz, ion balance 100 %

without air support:

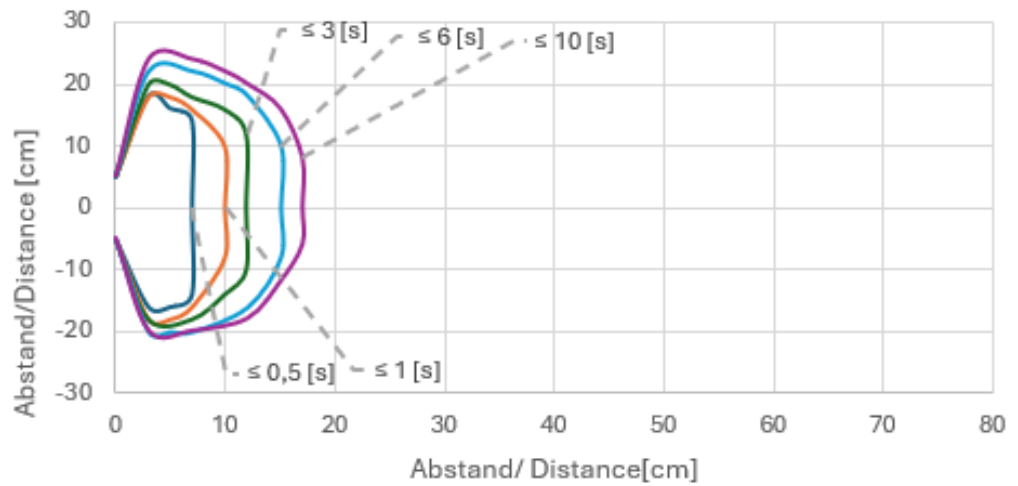

Fig. 10:

F00102y

with air support (1×10^5 Pa):

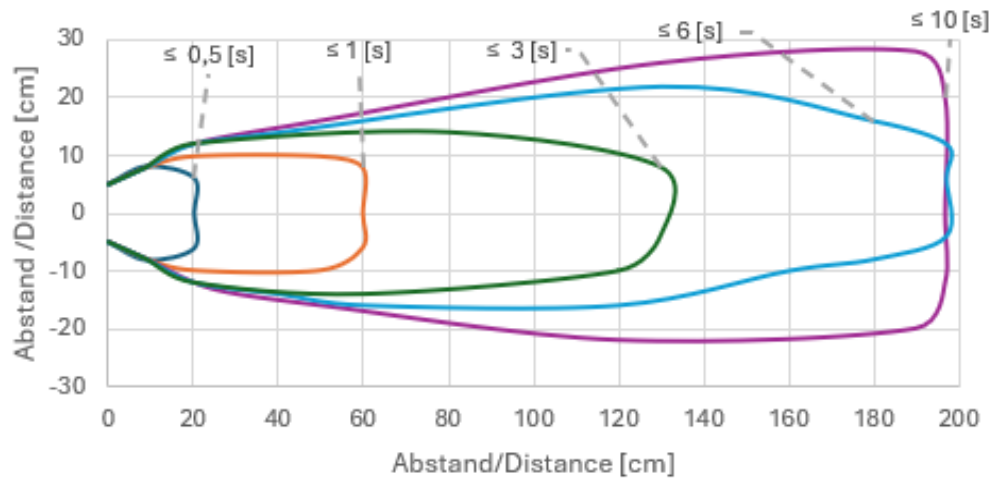

Fig. 11:

F00103y

Measuring conditions:

Duration of electrostatic discharge from ± 1000 V to ± 100 V with 150 x 150 mm Charged Plate Monitor (20 pF).

Ion balance* ± 3 V (in combination with ES61 power supply
[4.4 kV, 50 Hz, 100 % ion balance])

* at a distance of 100 mm without air support and relative humidity of
41.8 %

Complies with the following standards: ANSI-ESD-STM3.1,
RCJS-TR-5-4, JIS C 61340-4-7, IEC 61340-4-7 ED.2 Ion balance

8. Dimensions

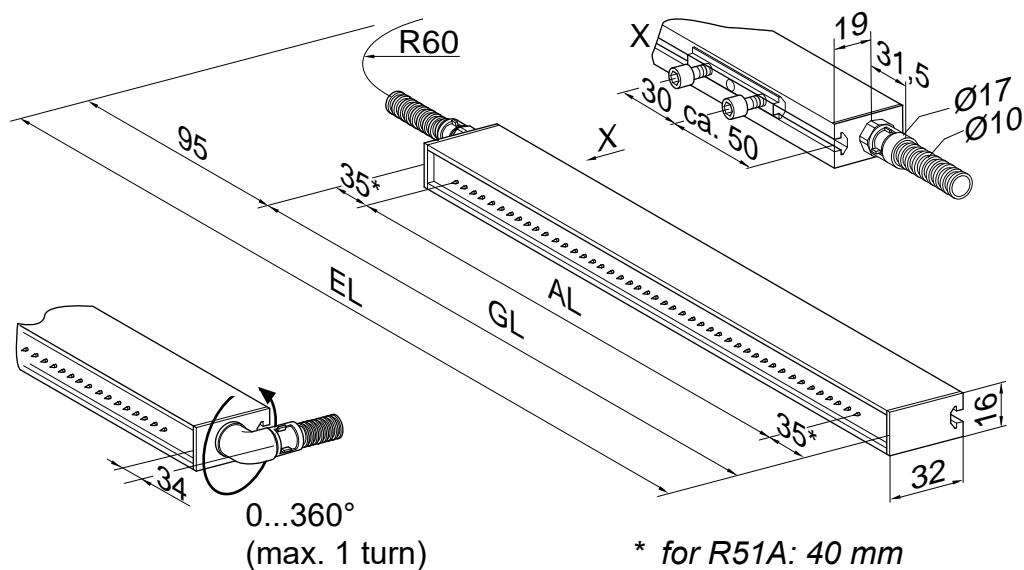
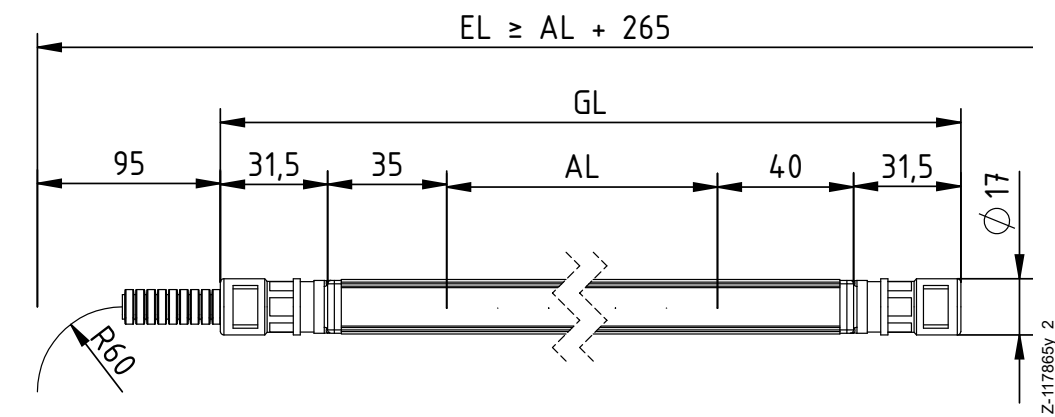
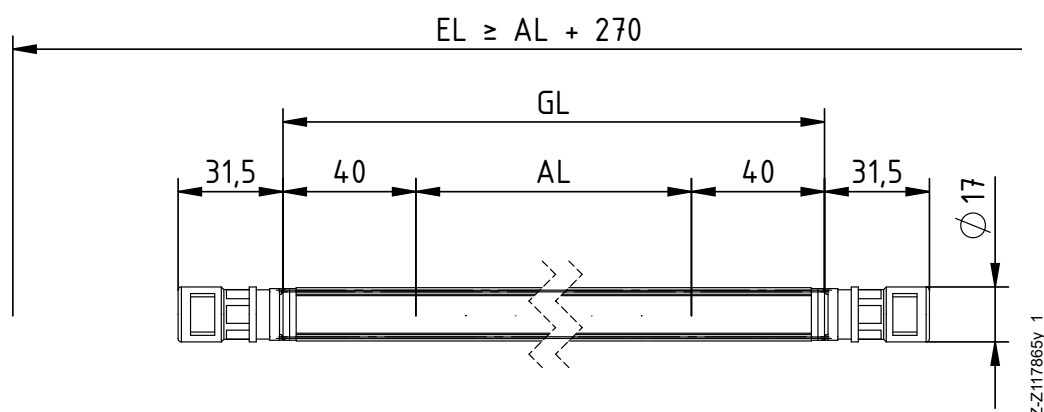

Fig. 13:
Design variant
R50/D
discharging bar
with an additional
axial connection



$EL =$ installation length $AL =$ active length $GL =$ total length

Fig. 14:
Design variant
R51A/D
discharging bar
with two axial
connections



9. Spare parts and accessories

Article	Article No.
High voltage distributor, discharging, 5 terminals (1 input, 4 outputs)	ESV
High voltage distributor, discharging, 4 terminals (1 high voltage cable, 4 outputs) (specify plug and socket type and cable length)	ESV61
High voltage distributor, discharging, 2 terminals (1 high voltage cable, 2 outputs) (specify plug and socket type and cable length)	ESVY61/_ _
Extension cable	KE/LB
High voltage cable with flexible tube from power supply ES5x / ES6x or distributor ESV / ESVY61/_S to bar R51A (specify cable length)	KE/LL_ _ _
High voltage cable without flexible tube from power supply ES5x / ES6x or distributor ESV / ESVY61/_S to bar R51A (specify cable length)	KE/SS_ _ _
Plug "L" Set for prefabricating the high voltage cable with flexible tube for power supply ES5x / ES6x / PI and distributor ESV /ESVY61/_S	103289
Plug "S" Set for prefabricating the high voltage cable without flexible tube for power supply ES5x / ES6x / PI and distributor ESV / ESVY61/_S	101366
Plug "Y" Set for prefabricating the high voltage cable with flexible tube for power supply ES24	111602
Plug "Z" Set for prefabricating the high voltage cable without flexible tube for power supply ES24	101406
Blanking plug for high voltage output	102742

Article	Article No.
Mounting material for bars:	
Slide nut with screws and washers	105826
Plastic countersunk screw, M5x8	101020
Plastic countersunk screw, M5x10	KSR00030
Plastic countersunk screw, M5x30	108525
Plastic cheese-head screw, M5x10	KSR00012
Plastic cheese-head screw, M5x16	KSR00013
Plastic cheese-head screw, M5x20	KSR00014
Plastic cheese-head screw, M5x25	KSR00015
Plastic cheese-head screw, M5x35	KSR00016
Plastic cheese-head screw, M5x50	KSR00017
Adapter plate, with screws 2 x M5 by 1 x M8	101807
Adapter plate for version S01 with screws 2 x M5 by 1 x M8	101824
GRP round rod Ø 20 mm	HAGFK/_ _
Bar holder for round rod	101075
Attachment clip for round rod	MCH02434
GRP reinforcement angle bracket	102568
Kit - Bar holder:	
Bar holder with clamps	HA01/_ _ _
Bar holder with perforated plate	HA02/_ _ _
Bar holder with assembly angle bracket	HA50/_ _ _
Cleaning brush with handle	RBR22
Volt Stick	109136
Operating Instructions (specify language)	BA-xx-2016

Please specify the article number when ordering.

EU-Declaration of Conformity

CE-2016-en-2411

Eltex-Elektrostatik-Gesellschaft mbH
Blauenstraße 67 - 69
D-79576 Weil am Rhein

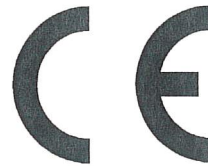

declares in its sole responsibility that the product

Discharging Bar Type R50 / R51A (according to Eltex reference code)

complies with the following directives and standards.

Relevant EU-Directive:

2014/35/EU

Low Voltage Directive

Harmonized standard applied:

EN 60204-1:2018

Safety of machinery – Electrical equipment of machines –
General requirements

Relevant EU-Directive:

2014/30/EU

EMC Directive

Harmonized standards applied:

EN IEC 61000-6-2:2019

Electromagnetic compatibility (EMC)
Generic standards – Immunity for industrial environments

EN 55011:2016 + A1:2017
+ A11:2020 + A2:2021

Industrial scientific and medical equipment –
Radio-frequency disturbance characteristics – limits and methods
of measurement

Relevant EU-Directives:

2011/65/EU

RoHS Directive

(EU) 2015/863

RoHS Delegated Directive

in the version effective at the time of delivery.

Eltex-Elektrostatik-Gesellschaft mbH keep the following documents for inspection:

- proper operating instructions
- plans
- other technical documentation

Weil am Rhein, 05.11.2024
Place/Date

Lukas Hahne, Managing Director

UKCA Declaration of Conformity

CA-2016-en-2208

Eltex-Elektrostatik-Gesellschaft mbH
Blauenstraße 67 - 69
D-79576 Weil am Rhein



declares in its sole responsibility that the product

Discharging Bar Type R50 / R51A (according to Eltex reference code)

complies with the following directives and standards.

Applicable Regulation:

S.I. 2016 No. 1101

Electrical Equipment (Safety) Regulations

Used Designated Standard:

BS EN 60204-1:2018

Applicable Regulation:

S.I. 2016 No. 1091

Electromagnetic Compatibility Regulations

Used Designated Standard:

BS EN IEC 61000-6-2:2019

BS EN 55011+A2:2016

Applicable Regulation:

S.I. 2012 No. 3032

RoHS Regulations

in the version effective at the time of delivery.

Eltex-Elektrostatik-Gesellschaft mbH keep the following documents for inspection:

- proper operating instructions
- plans
- other technical documentation

Weil am Rhein, 30.08.2022
Place/Date



Lukas Hahne, Managing Director

Eltex offices and agencies

The addresses of all
Eltex agencies can be
found on our website at
www.eltex.de



z01007y



Eltex-Elektrostatik-Gesellschaft mbH
Blauenstraße 67-69
79576 Weil am Rhein | Germany
Phone +49 (0) 7621 7905-422
eMail info@eltex.de
Internet www.eltex.de